

OPERATOR'S MANUAL

January 2005

AllmandTM

TLB SERIES

TLB 6235

ALLMAND BROS. INC
P.O. BOX 888
HOLDREGE, NE 68949

PHONE: 308/995-4495, 1-800/562-1373
ALLMAND FAX: 308/995-5887
ALLMAND PARTS FAX: 308/995-4883

AllmandTM **TLB SERIES**

For Parts and Updates visit Allmand on the Web at www.allmand.com

INSPECTION CHECK LIST

FOR PREPARING TLB 6235 FOR DELIVERY OR RENTAL

The **TLB 6235** requires service as well as proper operation in order to provide the performance and safety it has been designed for. Never deliver or put a machine into service with known defects or missing instructions or decals. Always instruct the customer in the proper operation and safety procedures as described in the operator's manual. Always provide the manual with the equipment for proper and safe operation.

CHECK LIST:

- Visually inspect the equipment to ensure that all instructions and decals are in place and legible.
- Inspect the hydraulic system to insure all connections are tight and secure.
- Lubricate all grease fittings with recommended grease.
- Inspect all hydraulic hose for proper routing and signs of damage.
- Check the condition of the hydraulic cylinders.
- Inspect the steering system, tie rod ends, spindles and wheel bearings and tighten rod ends regularly.
- Check the outriggers and make sure they operate properly.
- Tighten lug nuts to 80 ft/lb every 50 hours of operation.
- Inspect the loader and backhoe for damage and test for proper operation.
- Inspect the loader bucket stops for damage. (there should be at least 1/2" clearance between cylinder rod and bucket pin grease zerk).
- Inspect the electrical wiring for signs of damage.
- Inspect the park brake for proper holding strength.
- Inspect the tires to ensure good condition and proper inflation.
- Make sure the battery is fully charged and terminals are tight and clean. Insure the electrolyte is at the correct level.
- Check the service intervals for oil filters, fuel filter, air cleaner, engine oil and hydraulic oil.
- Check the engine oil, hydraulic oil and fuel levels.
- Start engine and check for hydraulic leaks.
- Check to make sure the operator's manual is with the equipment.
- Inspect the machine physically for damage and repair if necessary.

NOTE: See appropriate section of manual for scheduled maintenance intervals

- After completing the inspection checklist, operate the loader and backhoe through a complete operation cycle, following the operating instructions in the operator's manual.
-

WARNING

**NEVER ALLOW ANYONE TO OPERATE
THE EQUIPMENT WITHOUT PROPER TRAINING!**

ALWAYS READ THE INSTRUCTIONS FIRST!

INTRODUCTION

This manual provides the information necessary for the safe operation of the Allmand **TLB 6235**.

The **TLB 6235** standard configuration is powered by a diesel engine connected to hydrostatic pumps that drive hydraulic motors and cylinders that move the machine. Time should be taken to understand the controls and movement of this equipment.

Specific operating instructions and specifications are contained in this publication to familiarize the operator and maintenance personnel with the correct and safe procedures necessary to maintain and operate the equipment.

Take time to read this book thoroughly. If you are uncertain about any of the information presented in the manual, contact the factory by phone at **800-562-1373** or by fax at **308-995-5887** or contact your dealer, for clarification before operation.

SAFETY SYMBOLS

The purpose of the SAFETY INFORMATION SYMBOL shown below is to attract your special attention to safety related information contained in the text.

 **DANGER**

 **WARNING**

 **CAUTION**

FAILURE TO UNDERSTAND AND COMPLY WITH SAFETY RELATED INFORMATIONAL INSTRUCTIONS MAY RESULT IN INJURY TO OPERATOR OR OTHERS. IF YOU DO NOT UNDERSTAND ANY PART OF THIS INFORMATION CONTACT YOUR DEALER FOR CLARIFICATION PRIOR TO OPERATING EQUIPMENT.

NOTE

The word **NOTE** is used to bring your attention to supplementary information in relation to various aspects of proper operation and maintenance.

NOTE: Keep this manual accessible during operation to provide convenient reference.

NOTE: Any reference in this manual to **LEFT** or **RIGHT** shall be determined by looking forward while sitting in the operator's seat.

TABLE OF CONTENTS

INSPECTION CHECK LIST	2
INTRODUCTION	3
SAFETY SYMBOLS	3
TABLE OF CONTENTS	5
SAFETY DECALS	6-7
SAFETY	8-14
DESCRIPTION OF MODEL	15-17
OPERATOR'S STATION	18
SPECIFICATIONS	19-20
ENGINE OPERATION	21-23
OPERATING THE TLB 6235	24-26
HYDROSTAT DUMP VALVE OPERATION	26
MAINTENANCE	27
LUBRICATION	28
STORAGE	29
TROUBLESHOOTING	30-36
ISUZU HYDRAULIC SCHEMATIC	37
WIRING SCHEMATIC FOR OPTIONAL EQUIPMENT	38
WIRING SCHEMATIC FOR ISUZU 3CD1 ENGINE	39
SERVICE INFORMATION	40
FORWARD / REVERSE PEDAL "CREEP" ADJUSTMENT	40
FORWARD-REVERSE PEDAL LINKAGE ASSEMBLY	41
PARK BRAKE ADJUSTMENT	40
PARK BRAKE ASSEMBLY	41

SAFETY DECALS

SAFETY WARNING!

ALWAYS REPLACE ANY SAFETY AND INSTRUCTION DECALS THAT BECOME DAMAGED, PAINTED OR OTHERWISE ILLEGIBLE

Refer to these representations of the safety warning decals used on the TLB 6235 to insure correct ordering if replacing becomes necessary.

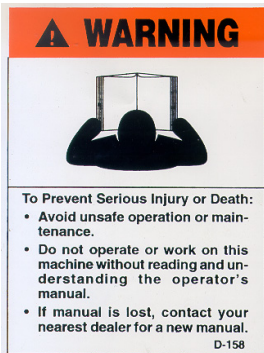

D-158

Cover panel - upper left



D-191

Cover panel - lower right



D-189

Frame Upright - right side



D-195

Rear Fender-Left of Seat

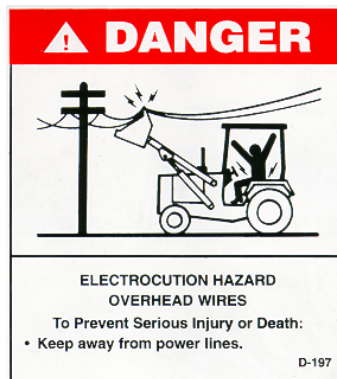

D-197

Rear Fender-Right of Seat

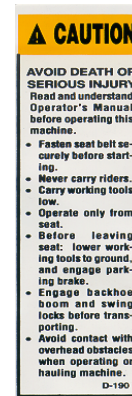

D-190

ROPS front left upright



D-194

ROPS front right upright

SAFETY DECALS

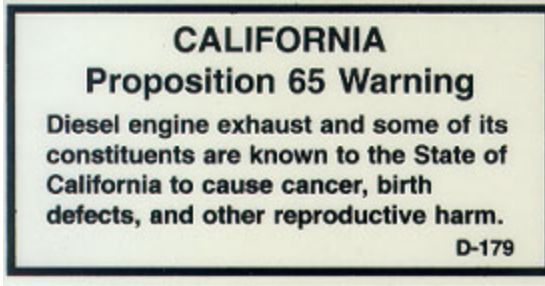

D-179
Right Frame Upright



D-147
On Directional Pedal



D-193
Right Frame Rail ahead
of Exhaust Pipe



D-034
Right Fender next to
Fuel Fill



D-196
Left Side of Throttle
Control

AVOID INJURY FROM ROLLOVER ACCIDENTS!

- ALWAYS WEAR YOUR SEAT BELT WHILE OPERATING THIS MACHINE.
- DO NOT ATTEMPT TO JUMP CLEAR OF A TIPPING MACHINE. SERIOUS OR FATAL CRUSHING INJURIES WILL RESULT. THIS MACHINE MAY TIP OVER FASTER THAN A PERSON CAN JUMP FREE.



TO AVOID ROLLOVERS:

- Be careful when operating on a slope.
- Avoid sharp turns at high speed.
- Balance loads so weight is evenly distributed and load is stable.
- Carry loads close to the ground to aid visibility and lower center of gravity.

DO NOT OVERLOAD: Know capacity of machine.

Be careful when operating at the edge of an excavation, trench, drop-off and loading or unloading from a trailer.



**USE
SEAT
BELT**

AVOID INJURY FROM BACK OVER ACCIDENTS!

- BEFORE MOVING MACHINE, BE SURE ALL PERSONS ARE CLEAR OF AREA.
- ALWAYS BE ALERT FOR BYSTANDERS MOVING INTO THE WORK AREA. SIGNAL TO WARN BYSTANDERS BEFORE MOVING MACHINE.
- WHEN USING A SIGNAL PERSON, KEEP PERSON IN VIEW AT ALL TIMES. BE SURE SIGNAL PERSON IS CLEAR BEFORE BACKING UP.



TO AVOID BACK OVER ACCIDENTS:

- Always look around before you back up. Be sure that everyone is clear of machine.
- Use a signal person when backing up if view is obstructed. Always keep signal person in view.
- Learn the meaning of all flags, signs and markings used on the job and who has the responsibility for signaling.
- Dust, heavy rain, fog, etc., can reduce visibility. As visibility decreases, reduce speed and use proper lighting.

PREVENT MACHINE RUNAWAY

- Avoid possible injury or death from machine runaway.
- Do not start engine by shorting across starter terminals.
- Never start engine while standing on the ground. Start engine only from operator's seat with transmission in neutral and park brake engaged.



AVOID INJURY FROM ROLLAWAY ACCIDENTS

- To prevent rollaway, always make sure machine is properly secured before leaving operator's seat.
- Death or serious injury may result if you attempt to mount or stop a moving machine.

- **TO AVOID ROLLAWAY:**
- Park machine on level ground.
- Engage park brake.
- Lower all equipment to ground.
- Stop the engine.
- Block the wheels if you park on a grade and position machine to prevent rolling.

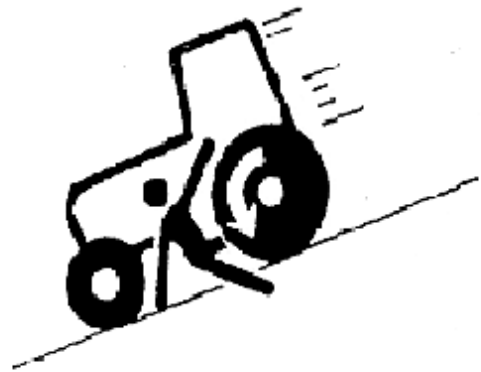

USE SEAT BELT PROPERLY

- Use seat belt when operating machine to reduce the chance of injury from an accident such as a rollover.
- It is important to use the seat belt on ROPS equipped machines to minimize the chance of injury from an accident such as a rollover.
- Keep the seat belt in good condition.
- Carefully examine buckle, webbing and attaching hardware.
- Be sure that attaching hardware is in place.



REPLACE THE SEAT BELT IF IT DOES NOT OPERATE PROPERLY, IS DAMAGED, WORN OR DETERIORATED IN ANY WAY.

USE HANDHOLDS AND STEPS

- **DO NOT** mount tractor from the drive pedal side.
- Falling is a major cause of personal injury.
- Always face the machine and use a three-point contact when mounting or dismounting the machine.
- Never jump either on or off the machine.
- Never mount or dismount a moving machine.
- Be careful of slippery conditions on platforms, steps and hand-rails when mounting or dismounting the machine.



DRIVE MACHINE SAFELY

AVOID DRIVING ON HILLSIDES OR STEEP SLOPES

- Set backhoe boom lock and swing lock to center the boom before driving.
- This is a potential rollover hazard and could result in a serious injury or possibly death.
- **If you must drive on steep hillsides**, moving the backhoe to the uphill side of the machine may make the machine more stable, depending upon working conditions.

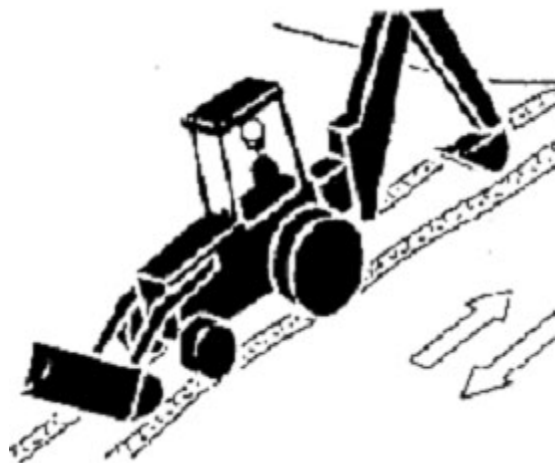

DRIVE CAREFULLY:

- On slopes (avoid if at all possible)
- Where space is limited
- Over rough ground, curbs and tracks
- Near a ditch or excavation **ALWAYS!**

FOR TRAVELING:

- Carry loader bucket low.
- Never carry passengers.



OPERATE BACKHOE SAFELY

Before digging:

- Check location of electrical cables
- Gas lines
- Water and sewer lines
- Avoid accidental machine movement

Before changing seats to operate the backhoe:

- Engage park brake.
- Lower loader bucket to the ground.

After changing positions to the rear backhoe seat:

- Lower stabilizers to the ground.
- Lift rear tires off the ground so as to remove the weight from the tires.



Otherwise, from the loader operator seat:

- Raise loader bucket and stabilizers
- Drive machine forward to change position
- Properly secure machine after each move.
- **DO NOT** dig under stabilizers!
- Stabilizers must be set on firm surfaces. Be alert to possible machine movement when raising stabilizers and loader bucket.
- Avoid swinging bucket to the downhill side of the machine when digging on a slope.
- Dump soil on the uphill side. If not, the machine has a possibility for rollover.
- Move boom slowly when raising loaded bucket to full height.
- Clear all persons from area of operation and machine movement.

HANDLE CHEMICAL PRODUCTS SAFELY

- Direct exposure to hazardous chemicals can cause serious injury. Potentially hazardous chemicals used with **TLB 535** equipment include such items as lubricants, coolants, paints and adhesives.
- A Material Safety Data Sheet (MSDS) provides specific details on chemical products, physical and/or health hazards, safety procedures and emergency response techniques.
- Check the MSDS before you start any job using a hazardous chemical.
- Follow recommended procedures and only use recommended and approved equipment.



WARN OTHERS OF SERVICE WORK

- Unexpected machine movement can cause serious injury or even death.
- Before performing any work on the machine, attach a “**DO NOT OPERATE**” tag to the steering wheel.



USE SAFETY LIGHTS AND DEVICES

- Install and use all safety lights and devices necessary to assure safe operation and local compliance.
- Keep all safety items in good condition. Replace any missing or damaged parts immediately.

THE TLB 6235 SHOULD NOT BE DRIVEN ON PUBLIC ROADS FOR ANY REASON.

- Trailer to job sites or from one work location to another.
- Slow moving vehicles, such as the TLB 6235, present a hazard that, if involved in an accident, could result in serious injury or possibly death.
- A few minutes spent loading and trailering the TLB 6235, may save some one's life.

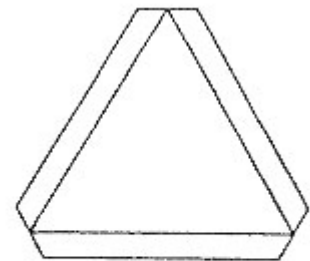

SLOW MOVING VEHICLE

THAT LIFE MIGHT BE YOURS!

PROTECT AGAINST FLYING DEBRIS

- Wear safety glasses or goggles to protect from flying debris.

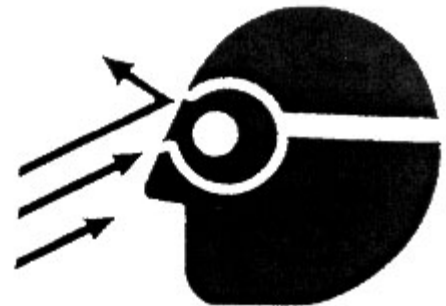

WEAR PROTECTIVE CLOTHING

- Wear close fitting clothing and safety equipment appropriate to the job.
- Operating equipment safely requires the full attention of the operator. Do not wear radio or music headphones while operating machine.



PROTECT AGAINST NOISE

- Prolonged exposure to loud noise can cause impairment or loss of hearing.
- Wear a suitable hearing protective device such as earmuffs or earplugs to protect against objectionable or uncomfortable loud noises.



AVOID POWER LINES

- Keep away from power lines. Serious injury or death may result. Never move any part of the machine or load closer to power lines than 3 m. (10 ft.) plus twice the line insulator length.

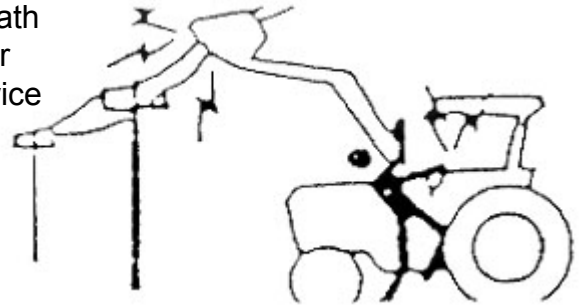

BEWARE OF EXHAUST FUMES

- Prevent asphyxiation. Engine exhaust fumes can cause sickness or death.
- If you must operate in a building, be sure there is adequate ventilation. Either use an exhaust pipe extension to remove the exhaust fumes or open doors and windows to bring in enough outside air into the area.



KEEP RIDERS OFF MACHINE

- Only allow the operator on the machine. Keep riders off.
- Riders on machine are subject to injury such as being struck by foreign objects and being thrown off of the machine.
- Riders also obstruct the operator's view, resulting in the machine being operated in an unsafe manner.

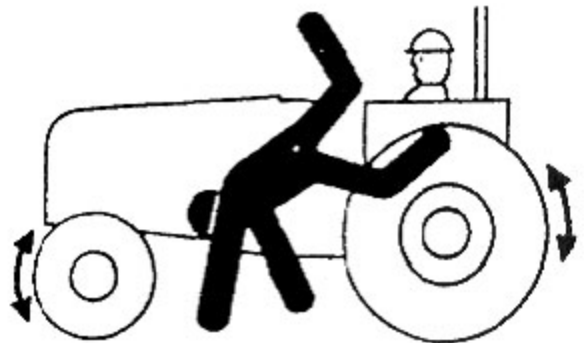

HANDLE FUEL SAFELY - AVOID FIRES

- Handle fuel with care, it is highly flammable. Do not refuel machine while smoking or when near open flame or sparks.
- Always stop engine before refueling machine. Do not fill fuel tank inside any building structure. Always attempt to refuel in the out of doors.



KEEP ROPS INSTALLED PROPERLY

Make certain all parts are reinstalled correctly if the roll-over protective structure (ROPS) has been loosened or removed for any reason.

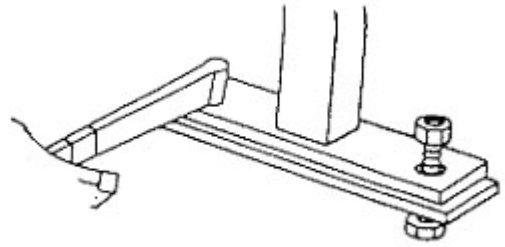

TORQUE ALL ½” MOUNTING BOLTS TO 37 lb./ft.



CAUTION

This Roll Over Protective Structure (ROPS) has been certified to industry and/or government standards. Any damage or alteration to ROPS, mounting hardware, or seat belt voids the certification and will reduce or eliminate protection for the operator in the event of a rollover. The ROPS, mounting hardware, (proper torque-37 lb./ft) and seat belt should be checked after the first 100 hours of machine operation and every 500 hours thereafter for any evidence of damage, wear, or cracks. In the event of damage or alteration, the ROPS must be replaced prior to further operation of the machine

DESCRIPTION OF MODEL

TLB 6235

GENERAL

The Allmand **TLB 6235** heavy-duty, compact tractor-loader-backhoe is designed for its size and maneuverability to excavate materials in areas that larger tractor-loader-backhoes can not access. The front end loader is generally used for excavating, leveling, and for back filling trenches and other types of excavations. The backhoe is generally used for excavation of soil to form a trench or opening, depending upon operator's needs, in areas where limited space is a factor.

The base unit consists of a chassis, engine, hydrostatic transmission drive system, tires and wheels, steering system, front end loader, hydraulic system, backhoe and Roll Over Protective Structure (ROPS).

CHASSIS WITH TWO SEPARATE HYDRAULIC RESERVOIRS

Provisions have been made in each reservoir for one 100 mesh suction strainers, a 1 1/2" oil fill opening, 1/2" NPT magnetic drain plug and oil level sight gauge. Each reservoir accomodates approximately 12 gallons of hydraulic fluid and has room for the oil to expand.

The chassis includes mounting provisions for solid rear axle, as well as the oscillating front axle.

The chassis also includes mounting provisions for a certified ROPS which is attached with specified hardware. The ROPS can be removed and replaced without affecting certification. Refer to page 14 of this manual for instructions on this operation.

HYDROSTATIC TRANSMISSION DRIVE SYSTEM

The machine is driven by an Eaton infinitely variable hydrostatic transmission consisting of a variable displacement pump and a fixed displacement motor. The pump unit includes a servo control valve.

Control of the variable displacement piston pump is the key to controlling vehicle speed. Prime mover horsepower is transmitted by the pump when the operator moves the directional control pedal. When the variable piston pump swash plate is tilted, a positive stroke to the piston is created.

This in turn, at any given input speed, produces a certain flow from the pump. This flow is transferred through high pressure lines to the motor. The ratio of the volume of flow from the pump to the fixed displacement of the motor will determine the speed of the motor output shaft.

Speed of the output shaft is controlled by adjusting the displacement flow of the transmission. Load (working pressure) is determined by the external conditions (grade, ground conditions, etc.) and this establishes the demand on the system.

Pump and motor are contained in separate housings. Oil is drawn directly from the reservoir into the hydrostatic charge pump. This oil then passes through a 500 psi 5 micron fiberglass pressure filter. This filter has an internal bypass valve that bypasses fluid to the reservoir when the filter becomes plugged.

The park brake is integral to the Comer front axle. The brake is activated by an adjustable hand lever conveniently located to the right of the operators seat.

POWER STEERING SYSTEM

The power steering is fully fluid linked. It consists of a manually operated load sensing steering control valve and a steering cylinder that is attached to the left and right steering arms. Fluid pressure is supplied from the load sensing gear pump to the steering control valve and is directed to the appropriate side of the steering cylinder. The steering control valve is a non-load reaction design which holds the axle position whenever the operator releases the steering wheel.

HYDRAULIC SYSTEM

Total system capacity is 25 gallons. Oil leaves the reservoir through two separate suction lines: one for the hydrostatic drive system and the other supplies the auxiliary hydraulic pump. The hydrostatic drive system draws fluid from the right reservoir through the 100 mesh suction strainer. The hydraulic transmission offers infinitely variable control of speed and direction. The operator has complete control of the **TLB 6235** with the control foot pedal for starting and stopping, in forward and reverse motion.

The auxiliary hydraulic circuit draws fluid through a 100 mesh suction strainer. Fluid enters the accessory pump which is a 8.0 g.p.m. gear type pump.

The circuit delivers fluid to the load-sensing steering control valve . Fluid out of the steering control valve returns to the reservoir. The remainder of the flow, approximately 8 g.p.m., enters the manual control valve which supplies fluid for control of the loader arm cylinders and loader bucket cylinders. The valve is equipped with a 2500 p.s.i. relief valve. Fluid to the backhoe is supplied by a power beyond port off the hydraulic control valve for the loader.

The loader control valve and backhoe control valve, both return through a 5 micron return filter with a pressure bypass. As in all hydraulic systems, reliability depends upon clean and cool oil.

LOADER

The loader assembly is manufactured to handle most excavation and landscaping projects. Critical locations on the loader arms and cylinder mounts are reinforced with plate steel to add durability. The pivot points of the loader are constructed of high strength steel to create a wear resistant joint.

The bucket assembly is manufactured to provide a structurally stable container to excavate, transfer, and load most types of product. The cutting edge is reinforced by a 1/2" thick grader blade material spanning the full width of the bucket. The bucket working capacity is 1/2 cubic yard.

TIRES and WHEELS

The **TLB 6235** is standard equipped with, 12-16.5 12 Ply tubeless tires for the front and 14-17.5 14 Ply tubeless tires for the rear. Recommended tire pressure for the rear tires is 75 psi max. Inflate front tires to 80 psi maximum.

BACKHOE

Refer to the ALLMAND Backhoe Operators Manual for any general information.

ENGINE - ISUZU DIESEL

Power is provided by a ISUZU 3CD1 32.7 HP., four-cycle, three cylinder, water cooled diesel engine. (Horsepower rating is made with engine at 3000 RPM) Engine includes: low oil pressure sensor, high water temperature sensor (these sensors operate warning lights on the dash panel. Tractor is not equipped with automatic shutdown systems), 12 VDC electrical system with starter, glow plugs, fuel solenoid and 20 amp. regulated alternator charging circuit. Features like full pressure lubrication, Zexel individual injection pumps, quick and easy access to routine service areas and use of quality, long lasting components provide a durable and dependable power source.

OPERATOR'S STATION

INSTRUMENT PANEL AND CONTROLS-DIESEL ENGINE MODELS

IMPORTANT: When the Low Engine Oil Pressure indicator is activated, stop engine immediately and investigate cause of problem. Do not restart engine until problem has been corrected.

IMPORTANT: When the High Water Temperature indicator is activated, do not stop engine. Reduce load and run engine at slow idle. If indicator remains on after several minutes, stop engine and allow cooling time before servicing engine.

IMPORTANT: When Engine Alternator Low Volts Indicator is activated, a problem is developing. It is not necessary to stop the engine immediately, but the cause should be investigated as soon as possible

- A FUEL TANK
- B OPERATOR'S MANUAL BOX
- C STEERING CONTROL
- D KEY SWITCH
- E ENGINE THROTTLE
- F GLOWPLUG INDICATOR
- G FRONT WORKLIGHT SWITCH
- H REAR WORKLIGHT SWITCH
- I HOUR METER
- J WARNING LIGHT CLUSTER GAUGE
- K OIL TEMPERATURE GAUGE
- L WATER TEMPERATURE GAUGE
- M FOOT PEDAL--FORWARD/REVERSE
- N LOADER HYDRAULIC CONTROL LEVER
- O PARK BRAKE

NOTE: Engine will not start unless foot pedal is in the neutral position.

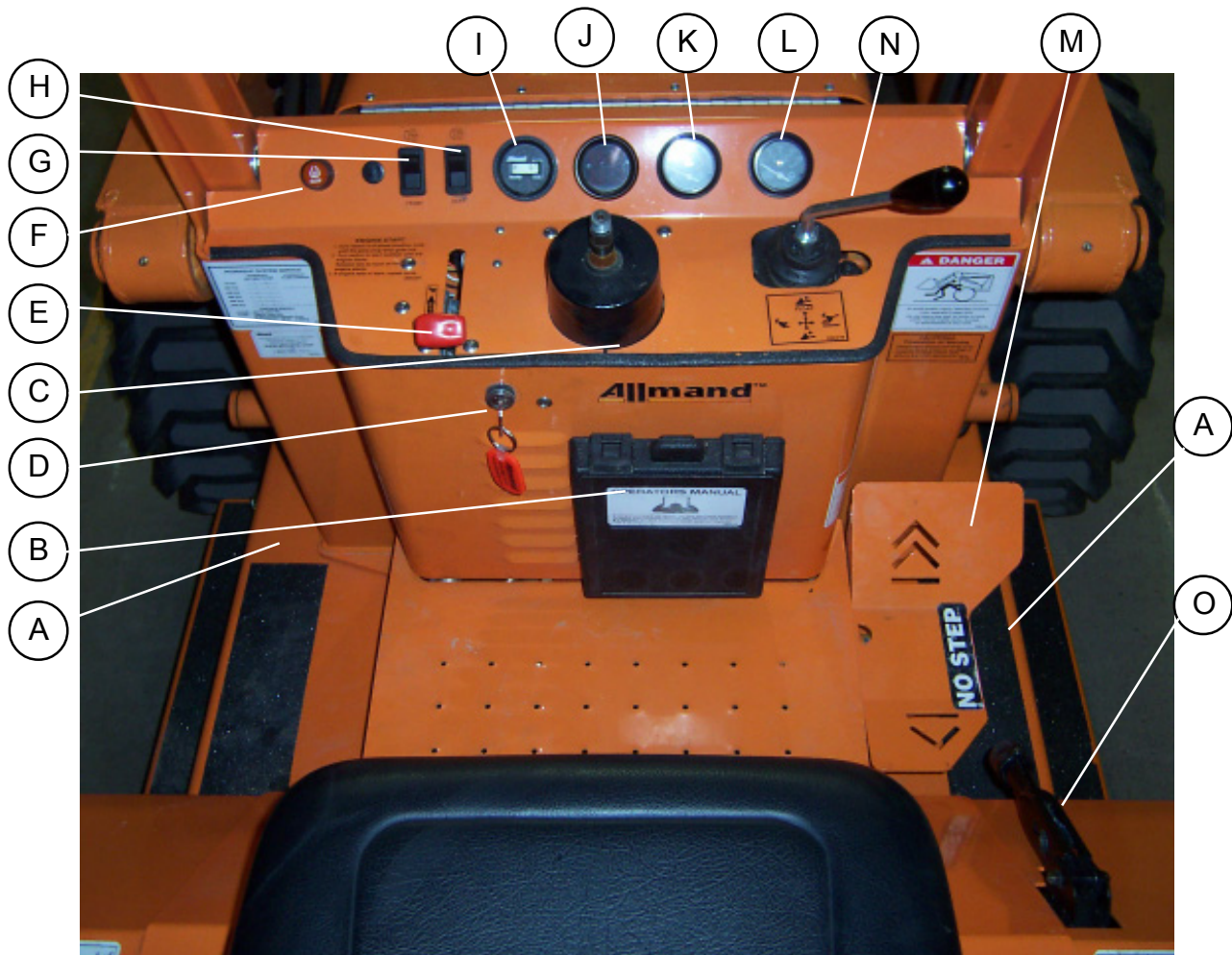

SPECIFICATIONS

OVERALL DIMENSIONS

▪ Weight	5800 lbs. (2631 kg)
▪ Length	18' 2" (5.5 m)
▪ Height	93" (2.4 m)
▪ Width	67" (1.7 m)
▪ Wheelbase	65" (1.7 m)
▪ Ground Clearance	11.5" (29.2 cm)

TRACTOR

▪ Engine	ISUZU 3CD1
▪ Transmission	Eaton HD Hydrostatic
▪ Drive motor	Eaton 82
▪ Power steering	Eaton Series 5
▪ Differential	Off Highway Planetary Limited Slip
▪ Brakes	Hydrostatic
▪ Parking brake	Integral to Front Axle
▪ Speed range	0 to 7.5 MPH
▪ Auxiliary hydraulic pump	Gear pump
▪ Auxiliary hydraulic output	8 gpm @ 2400 psi
▪ Fuel tank	12 gallons (45.4 L)
▪ Hydraulic oil reservoir	25 gallons (91 L)
▪ Tire size (Front)	12-16.5 12 Ply
▪ Tire size (Rear)	14-17.5 14 Ply
▪ Tire Pressure (Front)	80 psi maximum
▪ Tire Pressure (Rear)	75 psi maximum

LOADER

▪ Maximum lift height (Bucket Pivot)	110" (2.8 m)
▪ Clearance with bucket dumped	90" (2.3 m)
▪ Reach @ maximum height	20" (50.8 cm)
▪ Reach @ grade	67.5" (1.7 m)
▪ Bucket rollback angle	40 degrees
▪ Bucket dump angle	45 degrees
▪ Digging depth	5" (12.5 cm)
▪ Lift capacity	2100 lbs. (955 kg)
▪ SAE Lift capacity	1500 lbs. (682 kg)
▪ Breakout force	3400 lbs. (1545 kg)
▪ Bucket width	70"
▪ Bucket capacity	1/2 yd (.38 cu. m)

Specifications are subject to change without notice

HYDROSTATIC TRANSMISSION: EATON – MODEL 72400

Displacement	3.0 in ³ /r (49.2 cm ³ /r)
Flow @ rated speed and pressure	38.9 GPM (146.2 L/min.)
Speed, Input	3000 RPM (Max.)
Operating pressure (Max.)	3000 PSI (207 Bar) - Cont. 5000 PSI (345 Bar) - Inter.
Operating temperature	190 deg.F(87.deg.C)(Max.)

ENGINE - ISUZU - DIESEL

Model	3CD1
Type	Vertical, water cooled, 4-cycle diesel engine
Bore	3.3" (83 mm)
Stroke	3.54" (91 mm)
Displacement	91.3 cu. in. (1.5L)
Power @ 3000 RPM	32.7 HP*
Maximum torque @ 1800 RPM	66.9 ft-lbs (90.7 Nm)
Compression ratio	19:1
Weight	341lbs (155 kg)
Oil capacity	7.14 qts (6.7 L)
Lubrication	Forced lubrication by pump with full flow paper filter
Coolant capacity	2.13 Qts (2.0 L)
Cooling system	Pressurized radiator, forced circulation with water pump

**Horsepower ratings are established in accordance with Society of Automotive Engineers - Small Engine Test Code - J1349 GROSS.*

AXIAL PISTON MOTOR

- Motor series 74624
- Motor displacement 3.0cm³/rev.

FUEL REQUIREMENTS

Your ISUZU engine is designed to use either Number 1-D or Number 2-D diesel fuel. However, for better fuel economy, use Number 2-D diesel fuel whenever possible. At temperatures less than -7 deg C, (20 deg F), when Number 2-D may pose operating problems at colder temperatures, use Number 1-D fuel (if available) or use a “winterized” Number 2-D (a blend of Number 1-D and Number 2-D). Check with the service station operator to be sure you get the properly blended fuel. For more details on fuel see pages 16 through 19 in your Isuzu instruction manual.

ENGINE OIL REQUIREMENTS

Use a high quality engine oil of API (American Petroleum Institute) service class CC/CD. Refer to pages 21-22 in your Isuzu instruction Manual for more detailed engine oil requirements.

HYDRAULIC OIL REQUIREMENTS

Use a high quality multipurpose fluid with an SAE 20W/ISO 68 rating.

NOTE: The **TLB 6235** has been factory filled with HYDROCLEAR 9836.

ENGINE OPERATION

ENGINE BREAK-IN

OBSERVE ENGINE OPERATION CLOSELY

IMPORTANT: Become thoroughly familiar with the sound and feel of your new machine. Read and understand the Engine Instruction Manual included with your **TLB 6235**. Refer to the Engine instruction manual for seasonal fuel and oil viscosity recommendations.

NOTE: Engine is warranted to the original owner by the manufacturer.

OPERATOR RESPONSIBILITIES

- Check engine oil daily.
- Operate engine at normal loads.
- Check indicator lights and gauges (if equipped) frequently during operation.
- Avoid excess engine idling.
- Perform all engine maintenance in the Engine Instruction Manual.

NOTE: The engine owner is responsible for the performance of the required maintenance as defined by the engine manufacturer in the written instructions found in the Engine Instruction Manual provided with the engine.

CHECK INDICATORS BEFORE STARTING

Turn key switch clockwise and hold in the “RUN” position. All indicator lights must light. If any indicator fails to light, the bulb may be burned out. If bulb is not burned out and indicator fails to light up, see your authorized dealer or call the factory.

NOTE: Start engine only from the operator’s seat, with the foot pedal in the neutral position and the park brake engaged.

PRE-START CHECKLIST

- **CHECK** oil level, add if low. Do not overfill.
- **CHECK** fuel level, add if low.
- **CHECK** cooling air intake areas and external surfaces of engine. Make sure they are clean and unobstructed.
- **CHECK** that the air cleaner components and all shrouds, equipment covers and guards are in place and securely fastened.

CHECK forward / reverse pedal. Make certain that the pedal is exactly in neutral; if not, the engine will not start.



WARNING: LETHAL EXHAUST GASES

Engine exhaust gases contain poisonous carbon monoxide. Carbon monoxide is odorless, colorless and can cause death if inhaled. Avoid inhaling exhaust fumes.

NEVER RUN THE ENGINE IN A CLOSED BUILDING OR CONFINED AREA WITHOUT HAVING ADEQUATE VENTILATION!

ENGINE OPERATION

COLD WEATHER STARTING TIPS

1. Be sure to use the proper oil for the temperature expected.
2. Set speed control at part throttle position.
3. If possible warm the battery for more starting capacity.
4. Use fresh fuel at all times. Do not use diesel left over from summer.

COLD WEATHER WARM-UP

In extremely cold weather conditions, an extended warm-up period will be necessary.

Avoid operation of hydraulic systems until engine is thoroughly warmed up and all ice, snow and frozen mud has been removed from the machine.

NOTE: When hydraulic oil is cold it moves very slowly. Do not attempt machine operation until hydraulic oil has warmed and hydraulic systems function at close to normal times. Run engine at 1/2 speed for 15 to 20 minutes. Cycle all hydraulic systems to distribute warmed oil until all systems operate freely.

COLD WEATHER STARTING

Your **TLB 6235** is equipped with the **Isuzu Automatic Glow Plug Timer System** that automatically regulates your glow plug heat time by monitoring water temperature. (see chart). This assures that you will get the proper amount of glow time to facilitate cold weather starts while preventing excessive glow plug heat time that could lead to premature glow plug failure. Use the following procedure to start your **TLB 6235** in cold weather:

1. Place throttle control **midway** between the “**slow**” and “**fast**” positions.
2. Turn the key switch to the ON position. At this time, the glow plug indicator on the instrument panel will light for a predetermined time
3. When the glow plug indicator goes out, turn the key switch to the “**start**” position and start the engine. Release the key immediately when the engine starts. (If engine fails to start, repeat steps 2 and 3.)

NOTE: Do not operate starter for more than 10 seconds Allow 30 seconds to pass between starting attempts. Possible stater damage could result from excessive heat caused by cranking too long. starting attempts.

4. Warm up the engine at mid throttle without load. Insufficiently warming an engine can shorten its service life.

NOTE: If the engine develops sufficient speed to disengage the starter but does not keep running (a false start), the engine rotation must be allowed to come to a complete stop before attempting to restart the engine. If starter is engaged while the flywheel is rotating, the starter pinion and flywheel ring gear may clash, resulting in damage to the starter or flywheel ring gear.

NOTE: If the starter does not turn the engine over, stop cranking immediately. Do not make further attempts to start the engine until the condition is corrected. See your local ISUZU Engine Service Dealer for trouble analysis.

FOR A WARM ENGINE

Follow the same starting procedure as described for cold weather starting. Use of the glow plugs may not be necessary on a warm engine, and use of the glow plugs is not recommended in temperatures above 41° F.

IMPORTANT: Always check all the engine warning lights when starting. If the oil pressure light remains on, immediately stop the engine and check for the cause

STOPPING THE ENGINE

Before leaving the operator's station:

1. Park the machine on a level surface and lower loader bucket, backhoe bucket and any other accessories to the ground.
2. Engage park brake.
3. Place the throttle in the “**slow**” position. **Allow the engine to run at least 15 seconds before stopping the engine.**
4. Turn the key switch to the “**off**” position.
5. Move hydraulic control levers to release hydraulic pressure from the system.

CAUTION: PREVENT POSSIBLE INJURY FROM UNEXPECTED MACHINE MOVEMENT. NEVER RELY ON NEUTRAL POSITION OF FOOT PEDAL ALONE TO KEEP THE MACHINE FROM ROLLING. THE MACHINE CAN UNEXPECTEDLY ROLL OR MOVE UNDER POWER RESULTING IN SERIOUS INJURY OR DEATH. ALWAYS ENGAGE PARK BRAKE TO HOLD MACHINE STATIONARY!

ENGINE ANGLE OF OPERATION:

The **ISUZU diesel** engine can be operated at angles up to 25 degrees. Check oil level to assure crankcase oil level is at the full mark.

NOTE: Do not operate this engine continuously at angles exceeding 25 degrees in any direction. **Serious engine damage can occur from insufficient oil supply.**

COOLING:

NOTE: If debris builds up on the grass screen or other cooling air intake areas, stop the engine immediately and clean. Running this engine with blocked or dirty air intake and cooling areas can cause extensive damage due to overheating.

ENGINE SPEED:

NOTE: Do not tamper with the governor setting to increase the maximum engine speed. Over speed is hazardous and will void engine warranty. The maximum allowable high idle speed for this engine is **3000 RPM** with no load.

BATTERY:

- The **TLB 6235** is shipped with a 12 volt, group 24 battery with a 675 CCA rating.
- Check battery electrolyte level regularly and fill as needed.
- Replace with the same group size and amp rating when replacement is needed.

NOTE: The **TLB 6235** electrical system is a 12-volt negative (-) ground.

CAUTION: An explosive gas is produced while batteries are in use or being charged. Keep flames or sparks away from the battery area. Make sure batteries are charged in a well-ventilated area. Always wear eye protection when servicing or handling batteries.

OPERATING THE TLB 535

DRIVING ON PUBLIC ROADS

Become familiar with local laws and ordinances affecting driving on highways.
Use “slow moving vehicle” emblems to alert motorists.



CAUTION: USE OF A SEATBELT IS REQUIRED WHEN THE TLB 6235 IS IN OPERATION TO MINIMIZE THE CHANCE OF INJURY FROM AN ACCIDENT SUCH AS ROLL OVER.

OPERATING THE TRACTOR

1. Fasten seat belt
2. Retract backhoe bucket and dipperstick functions.
3. Raise backhoe boom, move it to the center, and engage boom lock.
4. Raise stabilizers
5. Switch position to the front facing seat.
6. Raise the loader bucket off the ground and roll bucket back.

PARKING THE MACHINE

Before leaving the operator’s station, do the following:

1. Park the machine on a level surface.
2. Lower all equipment to the ground.
3. Move the throttle to the “**slow**” position.
4. Move the forward / reverse pedal to the neutral position.
5. Engage park brake.
6. Operate engine at 1/2 speed without load for at least 15 seconds.
7. Turn the key switch to the “**off**” position, and remove key.
8. Release all hydraulic pressure from the system by moving all hydraulic controls until loader bucket and backhoe are resting on the ground or on the stops.

CAUTION: PREVENT POSSIBLE INJURY FROM UNEXPECTED MACHINE MOVEMENT. NEVER RELY ON NEUTRAL POSITION OF FOOT PEDAL ALONE TO KEEP THE MACHINE FROM ROLLING. THE MACHINE CAN UNEXPECTEDLY ROLL OR MOVE UNDER POWER RESULTING IN SERIOUS INJURY OR DEATH. ALWAYS ENGAGE PARK BRAKE TO HOLD MACHINE STATIONARY! IF PARKING ON A SLOPE, PUT BLOCKS ON THE DOWNHILL SIDE OF THE WHEELS TO PREVENT MOVEMENT.

FORWARD / REVERSE PEDAL

To change direction of movement on the **TLB 6235** use the forward / reverse pedal, located on the right side of the tractor frame.

NOTE: Reduce speed when changing directions of travel for safety.

1. Lightly depress the forward pedal with the toe of the right foot to travel forward.
2. Lightly depress the rear pedal with the heel of the right foot to travel in reverse.

NOTE: By lightly depressing the pedals forward and reverse, torque is developed to be transferred to the drive wheels by the hydraulic motor and differential set-up.

The further the forward and reverse pedals are depressed, the faster ground speed.

Torque will decrease as ground speed increases.

3. Move the forward / reverse pedal to the neutral position to stop.

NOTE: The pedal returns to a neutral detent position when pressure is released from the forward and reverse pedals.

LOADER CONTROL VALVE LEVER

The loader control valve returns to the neutral position when released, except when in the float position.

A - Move the control valve lever **forward** to **lower** loader arms.

AA - Move the control valve lever **forward** past the detent. This is the **float** position.

B - Move the control valve lever **back** to **raise** the loader arms.

C - Move the control valve lever **left** to **roll back** the bucket.

D - Move the control valve lever **right** to **dump** the bucket.

For faster loader cycle times follow these simple tips:

1. Run engine at fast idle.
2. Move the loader boom and the bucket at the same time.
3. **Without using force**, move control valve lever fully toward each function.

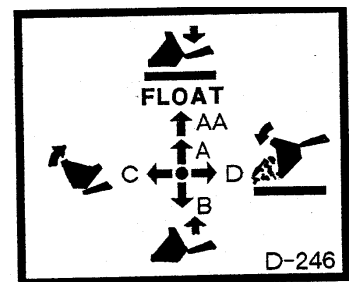

CAUTION

PREVENT POSSIBLE INJURY FROM UNEXPECTED MACHINE MOVEMENT, OPERATE THE LOADER ONLY WHEN YOU ARE IN THE OPERATOR'S SEAT FACING FORWARD.

OPERATING TIPS

- Reduce speed when driving over rough terrain, carrying heavy loads, or working in a congested area.
- Whenever possible, avoid obstacles, such as rough terrain, rocks, curbs and ditches.
- In general, by decreasing machine speed the control of the machine increases.
- When the backhoe is not in use, the backhoe boom must be locked in the fully raised position. Curl the backhoe bucket up and retract dipperstick.
- When driving the **TLB 6235**, carry the loader bucket low for good visibility and machine stability.
- Walk the job site to uncover any hazards and to plan the job.
- Practicing good housekeeping on the job site will help maximize machine stability, reduce operator fatigue, and increase productivity.
- Material that is loose and fragmented dumps much easier than material that is hard and compacted.
- Excavate material in thin layers rather than jamming it into the bucket. This will allow the material to break up as it enters the bucket. This is especially important when moving sticky, wet materials

- Clean the bucket by hand, if at all possible. If rapping the bucket against the stops is the only option, then do so using MINIMUM force, to prevent cylinder damage.
- DO NOT try removing stuck material from the bucket by striking it against the ground or another object.

PREPARING TO OPERATE BACKHOE

1. Position loader bucket flat on the ground. Lower loader arms to raise wheels off the ground.
2. Engage park brake.
3. Switch seats to position operator facing the backhoe.
4. Lower stabilizers to level unit.
5. Disengage swing lock and backhoe boom lock.

PREPARING TO OPERATE LOADER AFTER OPERATING BACKHOE

1. Retract backhoe bucket and dipperstick functions. Raise backhoe boom.
 2. Center boom and engage boom lock.
 3. Raise stabilizers.
 4. Switch seats to position operator facing the front end loader.
- Roll back loader bucket until bottom is parallel with the ground.

HYDROSTAT DUMP VALVE OPERATION

The purpose of the dump valve is to allow the movement of a disabled vehicle or if you have a vehicle that you just want to push a short distance, without starting the engine. When a hydrostatic driven vehicle is shut down it is virtually impossible to move the vehicle without opening the hydrostatic closed loop circuit. If an attempt is made to move the vehicle the hydraulic motor between the high pressure backplate of the pump and the motor. To overcome this condition, a dump valve is installed between the high pressure backplate of the pump and the motor. The dump valve is a plug that stem which has a flat between the two ends of relief valves. When the “closed position”, the stem is also in the closed position as shown in the top illustration.

Operation of Dump Valve

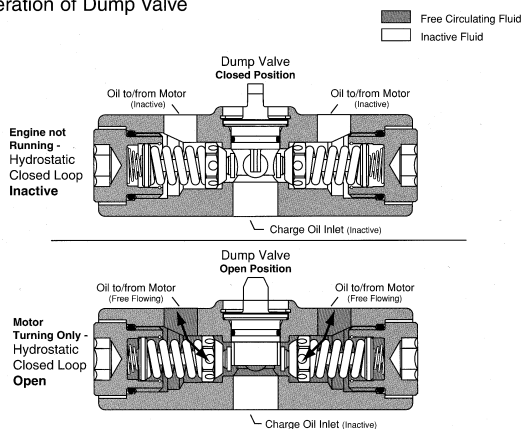

closed loop circuit. When the dump valve stem is rotated 90 degrees, the flat spade end spreads the relief valves to the “open position” as shown in the lower illustration. This allows the oil in the hydrostatic closed loop to “by-pass” around the high pressure relief valves side the pump backplate. The by-passing of oil inside the pump backplate will allow the motor to rotate freely when the vehicle is moved a short distance. The dump valve is intended only for moving a vehicle a very short distance and not intended for towing a vehicle behind a truck or tractor.

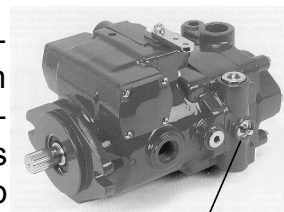

DUMP VALVE LOCATION

When the dump valve stem is rotated 90 degrees, the flat spade end spreads the relief valves to the “open position” as shown in the lower illustration. This allows the oil in the hydrostatic closed loop to “by-pass” around the high pressure relief valves side the pump backplate. The by-passing of oil inside the pump backplate will allow the motor to rotate freely when the vehicle is moved a short distance. The dump valve is intended only for moving a vehicle a very short distance and not intended for towing a vehicle behind a truck or tractor.

NOTE: serious damage to the hydrostatic drive will result if vehicle is towed. The dump valve must be completely closed prior to normal operation of the vehicle.

MAINTENANCE

MAINTENANCE INSTRUCTIONS



WARNING: Accidental Starts!

Before servicing the engine or equipment, always remove the ignition keys to insure there will not be any accidental start up. Make sure the equipment is in neutral and park brake set.

MAINTENANCE SCHEDULE

These required maintenance procedures should be performed at the frequency stated in the table. They should also be included as part of any seasonal tune-up.

NOTE: Every 500 hours of operation, separate the pump from the engine. Clean the splined areas and lightly grease the male portion of the pump spline. Use either Dow Corning G-N Metal Assembly Paste or #77 Assembly Paste. When remounting the pump, be certain the mating surfaces are clean and correctly aligned.

NO.	CHECKPOINTS	HOURLY INTERVALS						
		8	50	200	250	500	750	1000
1	Check engine oil level, fill if needed	X						
2	Change engine oil with seasonal viscosity		X		X	X	X	X
3	Cooling system circuit cleaning							X
4	Check battery electrolyte level	X			X			
5	Replace oil filter cartridge		X			X		X
6	Check fan belt for tightness	X			X		X	
7	Check oil cooler fins, clean as necessary	X			X		X	
8	Check fuel tank for sediment, clean as necessary				X			X
9	Check radiator hoses and clamps for leaks	X				X		
10	Starter and alternator check							X
11	Check fuel lines for leaks	X						
12	Check air cleaner element	X	X					
13	Replace air cleaner element							X
14	Check electrical wiring for damaged or loose connections	X	X		X			
15	Tighten tie rods to 35 ft/lbs.	X	X		X	X	X	X
16	Tighten lug nuts to 80 ft/lbs.	X	X		X	X	X	X
17	Check hydraulic oil level, fill if necessary	X	X					
18	Check all fasteners for tightness	X			X			
19	Check backhoe bucket teeth, replace if necessary	X						
20	Grease all swivel points (loader and backhoe)	X						
21	Clean or replace suction strainers				X			X
22	Grease right foot pedal mount and center bearing mount				X			
23	Check fuel filter, replace if necessary						X	
24	Check hydraulic hoses for damage and loose connections	X	X		X			X
25	Change hydraulic return filter		X	X		X		
26	Change hydraulic fluid				X			X
27	Check loader bucket stops for damage		X					

O - Indicates that jobs must be done after the first 5 hours respectively.

* - Perform these maintenance procedures more frequently under extremely dusty and dirty working conditions.

Hydraulic fluid should be changed every 1000 hours after the first 250 hour change.

NOTE: All daily checks should be done with every engine oil change.

NOTE: Change hydraulic return filter at the first 50 hours then every 200 hours.

LUBRICATION

The following diagram will direct maintenance personal to the lubrication points that will need to be greased on a daily schedule. Use of a multi-purpose grease is recommended.

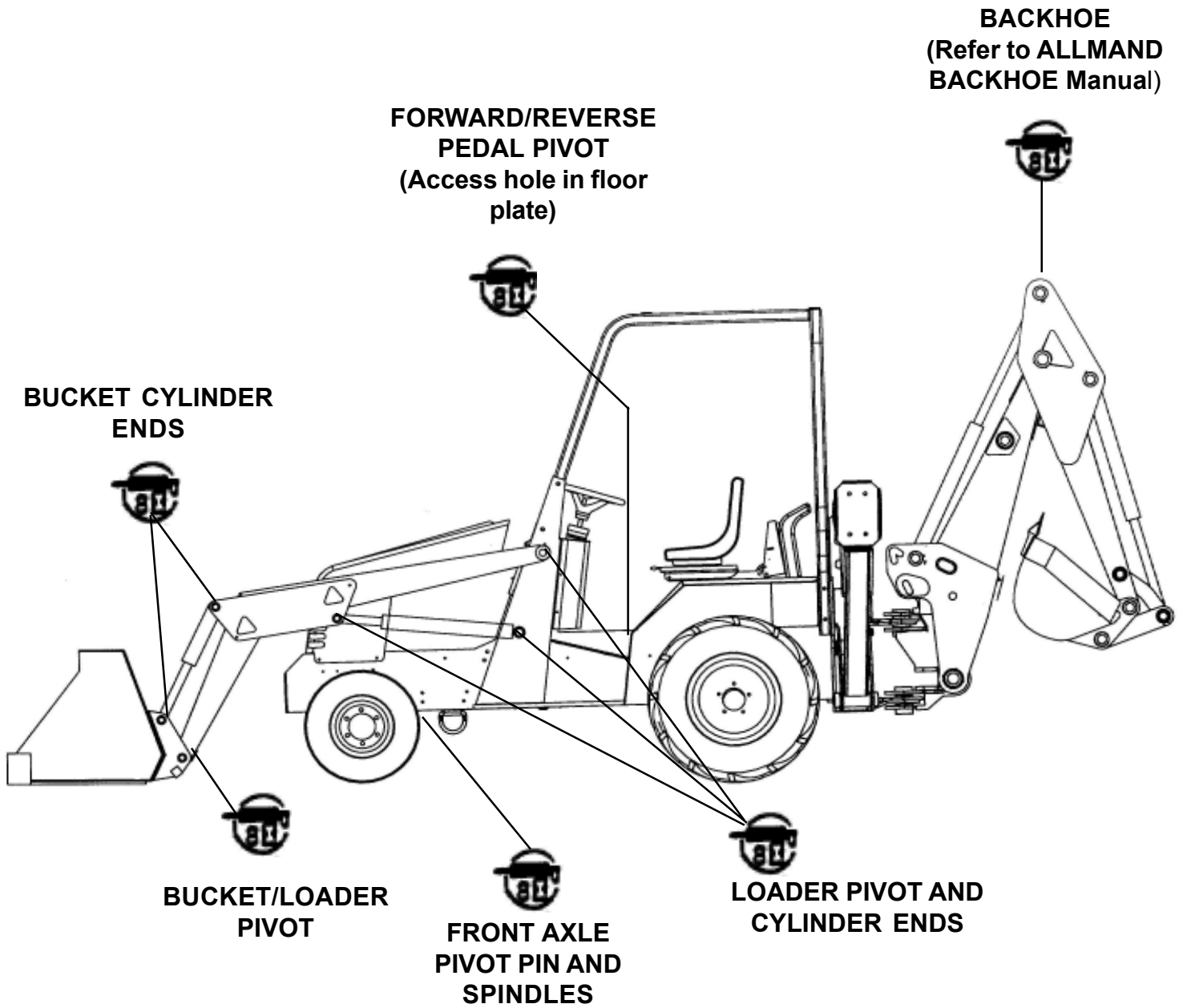

PREPARATIONS FOR STORAGE

1. When preparing the **TLB 6235** for storage, first remove seat mount plate and steering column cover. Wash off all dirt and grease from all the major components and connecting hoses. Coat the exposed cylinder rods with grease and grease all the grease fittings.
2. **IMPORTANT:** When washing the **TLB 6235**, allow engine and hydraulic system to cool before washing. Cold water on a hot engine or hydrostatic pump can cause costly damage. **DO NOT** direct the stream of water, when washing, directly at the hydraulic system breather, it is possible to get water into the hydraulic system and contaminate the fluid.
3. Make sure the battery is fully charged, battery terminals are clean and have a corrosion protectant applied.
4. Change the engine oil and run for 5 minutes to allow the oil to penetrate to all the parts.
5. Fill the fuel tank with fuel and add a fuel stabilizer to prevent the diesel fuel from gumming up the fuel system during storage.
6. Place the **TLB 6235** in a clean, dry place and cover if at all possible.

TROUBLESHOOTING

GENERAL

Proper troubleshooting begins with an organized approach to the problem at hand. Begin with investigation of the most probable cause, following the guidelines below.

Study the problem thoroughly before taking action:

- Did warning signs precede the problem? If so, what were they? What would they indicate?
- Is scheduled maintenance current on all parts and systems involved?
- Has similar trouble occurred before? What action was taken at the time?
- Can the engine be operated without further damage?



CAUTION

IF RUNNING INSPECTION MUST BE MADE, GET ASSISTANCE. OPERATOR SHOULD REMAIN SEATED ON MACHINE THROUGHOUT INSPECTION. SET PARKING BRAKE. MAKE SURE TRANSMISSION IS IN NEUTRAL POSITION.

Check the most convenient things first:

- Don't begin major work before checking all other possibilities.
- Reconsider all known facts and clues before proceeding to more in-depth work.

Correct the basic cause:

- Remember, failure of a certain part may be caused by a malfunction of another part or system.

SCHEMATICS:

This troubleshooting section incorporates electrical schematic diagrams formatted for ease of use by maintenance and for the training of personnel.



WARNING

THE TROUBLESHOOTING CHART AND PROCEDURES OUTLINED IN THIS SECTION SHOULD NOT BE ATTEMPTED BY OTHER THAN EXPERIENCED MECHANICS OR PERSONNEL UNDER THE DIRECT SUPERVISION OF AN EXPERIENCED MECHANIC. FAILURE TO COMPLY MAY RESULT IN DAMAGE TO EQUIPMENT AND/OR INJURY OR DEATH TO PERSONNEL.

TROUBLESHOOTING CHART

The troubleshooting chart lists problems that might be encountered in the operation of the **TLB 6235**. The remedies listed may direct the repairman to a possible faulty component.

A - ENGINE

- For engine troubleshooting charts indicating faults and recommended repair procedures, refer to Manufacturer's Operation and Maintenance Manual.
- If your particular problem is not covered or you are unsure of what steps to take, contact factory for assistance.

C – TRANSMISSION

TLB 6235 fails to move under power:

- Parking brake set
- Inadequate oil level in hydraulic reservoir
- Control pedal or linkage broken or loose
- Inadequate oil flow through transmission suction filter
- Drive coupling mechanical failure
- Hydrostatic pump failure
- Drive motor failure
- Charge loup filter plugged

TLB 6235 moves in neutral:

- Control pedal neutral centering device broken or out of adjustment.
- Neutral centering device return spring broken.

For detailed troubleshooting information on hydrostatic transmission, refer to Trouble Shooting Manual, Eaton Hydrostatic Transmissions, available from an Eaton representative or dealer.

C – ELECTRICAL SYSTEM

ENGINE STATUS	VOLTMETER READING	INDICATES	TO CORRECT
Running	13.5 to 14 volts	Normal Condition	None
Running	Less than 13.5 volts or more than 14 volts	Alternator or Regulator Malfunction	Contact Dealer
Won't Start	12 to 12.5 volts	Weak Battery	Charge Battery
Won't Start	Less than 12 volts	Weak Battery or Defective Battery Cell	Charge or Replace Battery
Stopped	Excessive current draw	Short Circuit	Inspect System

D - HYDRAULIC SYSTEM

- Thoroughly review description of hydraulic system, pages 16 and 17 of this text.
- Use logical steps to determine cause of malfunction.
- Identify the function or functions which require troubleshooting.
- If possible, trace malfunction to source: pump, control, motor or cylinder.
- Determine if pressure or volume is inadequate for function as specified.

D - HYDRAULIC SYSTEM (continued)

Hydraulic System Pressures:

- Steering Circuit 1500 p.s.i.
- Main circuit 2400 p.s.i.

Hydraulic System Flows:

- Main circuit 8 g.p.m.
- (Main circuit flow determined by R.P.M.)

PROBLEM	POSSIBLE CAUSE	CORRECTION
NO LOADER LIFT OR BUCKET ROOLBACK	Inadequate pressure	Inspect, clean or replace relief valve
INAPPROPRIATE LIFT SPEED	Cold hydraulic fluid	Warm hydraulic fluid by running engine
	Low engine R.P.M.	Move throttle control to fast position to increase R.P.M.
TRACTOR LOOSES DRIVE AND AUXLARY POWER	Hydraulic components my be loose from back of engine	Inspect input shaft and flywheel plate for damage. Replace parts if needed

STEERING

Most steering problems can be corrected if the problem is properly defined. The entire steering system should be evaluated before removing any components. The steering control unit is generally not the cause of most steering problems. The following is a list of steering problems along with possible causes and suggested corrections.

PROBLEM	POSSIBLE CAUSE	CORRECTION
SLOW STEERING, HARD STEERING OR LOSS OF POWER ASSIST	Worn or malfunctioning pump	Replace pump
	Malfunctioning relief valve allowing system pressure to be too low	Replace the relief valve
	Overloaded steering axle	Reduce the load
	Leaking or kinked load sensing signal line	Correct
WANDERING, VEHICLE WILL NOT STAY IN A STRAIGHT LINE	Worn mechanical linkage	Repair or replace
	Bending of linkage or cylinder rod	Repair or replace
	Loose cylinder piston	Repair or replace
	Severe wear in steering orbitrol	Repair or replace
DRIFTS-VEERS SLOWLY IN ONE DIRECTION	Worn or damaged steering linkage	Replace linkage and align front end

STEERING (continued)

PROBLEM	POSSIBLE CAUSE	CORRECTION
SLIP-SLOW MOVEMENT OF STEERING WHEEL FAILS TO CAUSE ANDY MOVEMENT OF STEERED WHEELS	Leakage of cylinder piston seals or accessory valve between cylinder line or ports	Replace seals or accessory valve
	Worn steering control unit meter	Replace steering control unit
TEMPORARY HARD STEERING OR HANG-UP	*Thermal shock	Check unit for proper operation and cause of thermal shock
ERRATIC STEERING	Air in system due to low level of oil, cavitation of pump, leaky fitting, pinched hose, etc.	Correct condition and add fluid
	Loose cylinder piston	Replace cylinder
	*Thermal shock damage	Replace steering control unit
	Sticking flow control cartridge in gear pump	Replace flow control cartridge or gear pump
"SPONGY" OR SOFT STEERING	Air in hydraulic system. Most likely air trapped in cylinder or lines	Bleed air out of system
	Low fluid level	Add fluid and check for leaks
FREE WHEELING- STEERING WHEEL TURNS FREELY WITH NO FEELING OF PRESSURE AND NO ACTION OF STEERED WHEELS	Steering column upper shaft is loose or damaged	Tighten steering wheel nut
	Steering control unit meter has a lack of oil. This can happen in start-up, after repair, or long periods of non-use	Usually starting engine and allowing hydraulic oil to circulate will cure the problem
	No flow to steering control unit- Can be caused by:	
	Low fluid level	Add fluid and check for leaks
	Ruptured hose	Replace hose
	Internal steering control unit damage due to "Thermal Shock"	Replace the steering control unit

*Thermal Shock is defined on the following page.

STEERING (continued)

PROBLEM	POSSIBLE CAUSE	CORRECTION
FREE WHEELING-- STEERING WHEEL TURNS WITH SLIGHT RESISTANCE BUT RESULTS IN LITTLE OR NOT STEERED WHEEL ACTION	Cylinder piston seal blown out	Determine the cause. Correct the cause and replace the blown seal
EXCESSIVE FREE PLAY AT STEERING WHEEL	Loose steering wheel nut. Steering column shaft worn or damaged. There should be very little play in the unit itself	Repair or replace steering wheel connection or column
EXCESSIVE FREE PLAY AT STEERED WHEEL	Broken or worn linkage between cylinder and steered wheels	Check anchor points in steering linkage between cylinder and steered wheels
	Leaking cylinder seals	Replace cylinder seals
STEERING UNIT LOCKS UP	Large particles in meter section	Clean the unit
	Insufficient hydraulic power	Check hydraulic power supply
	Severe wear and/or broken pin	Replace the unit
	*Thermal shock	Replace the unit
STEERING WHEEL OSCILLATES OR TURNS BY ITSELF	Parts assembled wrong. Steering unit improperly timed	Correct timing
STEERED WHEELS TURN IN WRONG DIRECTION WHEN OPERATOR ACTIVATES STEERING WHEEL	Lines connected to wrong steering cylinder ports	Reconnect lines correctly
ENGINE SOUNDS LIKE IT IS UNDER LOAD BUT FREES WHEN STEERING WHEEL IS TURNED	O-rings in the load sense relief cartridge are worn or missing	Replace o-rings

***Thermal Shock** - A condition caused when the hydraulic system is operated for some time without turning the steering wheel so that fluid in the reservoir and system is hot and the steering control unit is relatively cool (more than 50°F temperature differential). When the steering wheel is turned quickly the result is temporary seizure and possible damage to internal parts of the steering control unit. The temporary seizure may be followed by total free wheeling.

LOADER LIFT AND BUCKET ROLL BACK

The entire system should be evaluated before removing any components. The following is a list of problems with possible causes and suggestions for correction.

NOTE:

- It is important to check the loader bucket stops periodically for damage. If the stops are worn, the cylinder rods may come in contact with the bucket pin grease zerk.
- Check clearance between the rod and the zerk with the bucket rolled to the dump position. There should be a minimum of 1/2" clearance. If not, you must weld on the stop to increase clearance.

PROBLEM	POSSIBLE CAUSE	CORRECTION
SLOW LIFT OR ROLL BACK, LOSS OF POWER	Worn or malfunctioning pump	Repair or replace pump
	Stuck relief valve cartridge	Repair or replace pump
	Worn pump allowing system pressure to be less than specified	Repair or replace pump
SURGING OF LOADER AND BUCKET ACTIONS	Air in the system due to low level of oil, cavitation of pump, leaky fitting, pinched hose, etc.	Determine the cause and correct the problem
	Worn or binding of mechanical linkage	Repair or replace pump linkage
	Bending of linkage or cylinder rod	Repair or replace pump
	Loose cylinder piston	Repair or replace pump
LOADER AND BUCKET ACTIONS TOO SLOW	Cold hydraulic fluid	Warm fluid with engine at idle speed
	Engine speed is too low	Open throttle
	Oil leaking past control valve	Repair or replace worn section
	Oil too heavy	Use recommended oil
	Pump damaged or worn	Repair or replace pump
	Oil leaking past cylinder seals	Replace seals
	Dirty return oil filter	Replace return oil filter
	Faulty relief valve	Clean or replace relief valve

LOADER LIFT AND BUCKET ROLL BACK (continued)

PROBLEM	POSSIBLE CAUSE	CORRECTION
LOADER FAILS TO HOLD UP A LOAD	Broken or leaking lines	Replace defective hose and check for leaks
	Dirty hydraulic oil	Drain and refill oil, replace filter
	Oil leaking past cylinder seals	Replace seals
	Oil leaking past control valve	Repair or replace worn section
	Faulty relief valve	Clean or replace relief valve
OIL OVERHEATING	Dirty oil	Drain and refill oil, replace filter
	Partially plugged suction strainer	Drain oil, clean suction strainer and refill with new oil
	Control valve held open too long	Return control to neutral position when not in use
	Worn pump	Replace pump
	Relief valve set too low	Reset relief valve correctly
	Oil too light for warm weather	Use recommended oil
	Engine R.P.M. too fast	Reduce throttle setting
	Damaged oil lines	Replace damaged lines
	Excessive oil flow over relief valve from poor operating techniques	Learn smoother operating techniques
	Plugged or bent oil cooler fins	Clean and or straighten oil cooler
EXTERNAL LEAKAGE	Control valve tie bolts loose (if equipped)	Torque bolts sequentially-50, 70, 90 in/lb.
	Damaged o-rings between valve sections	Replace o-ring between valve sections
	Damaged o-rings on valve spool	Repair control valve
	Cylinder seals damaged	Repair cylinder seal
	Damaged o-rings on valve drop check	Repair control valve
	Broken oil lines	Replace hose
	Loose hydraulic fittings	Tighten fittings
CYLINDER MALFUNCTIONING	Oil leaks past seal	Replace seal
	Faulty relief valve	Clean or replace valve
CONTROL VALVE STICKING OR WORKING HARD	Dirty valve	Clean valve
	Scored bore or bent spool	Replace valve section
	Control linkage misaligned	Correct misalignment
	Return spring broken or binding	Replace spring
	Foreign matter in spool bore	Clean bore

ISUZU HYDRAULIC SCHEMATIC

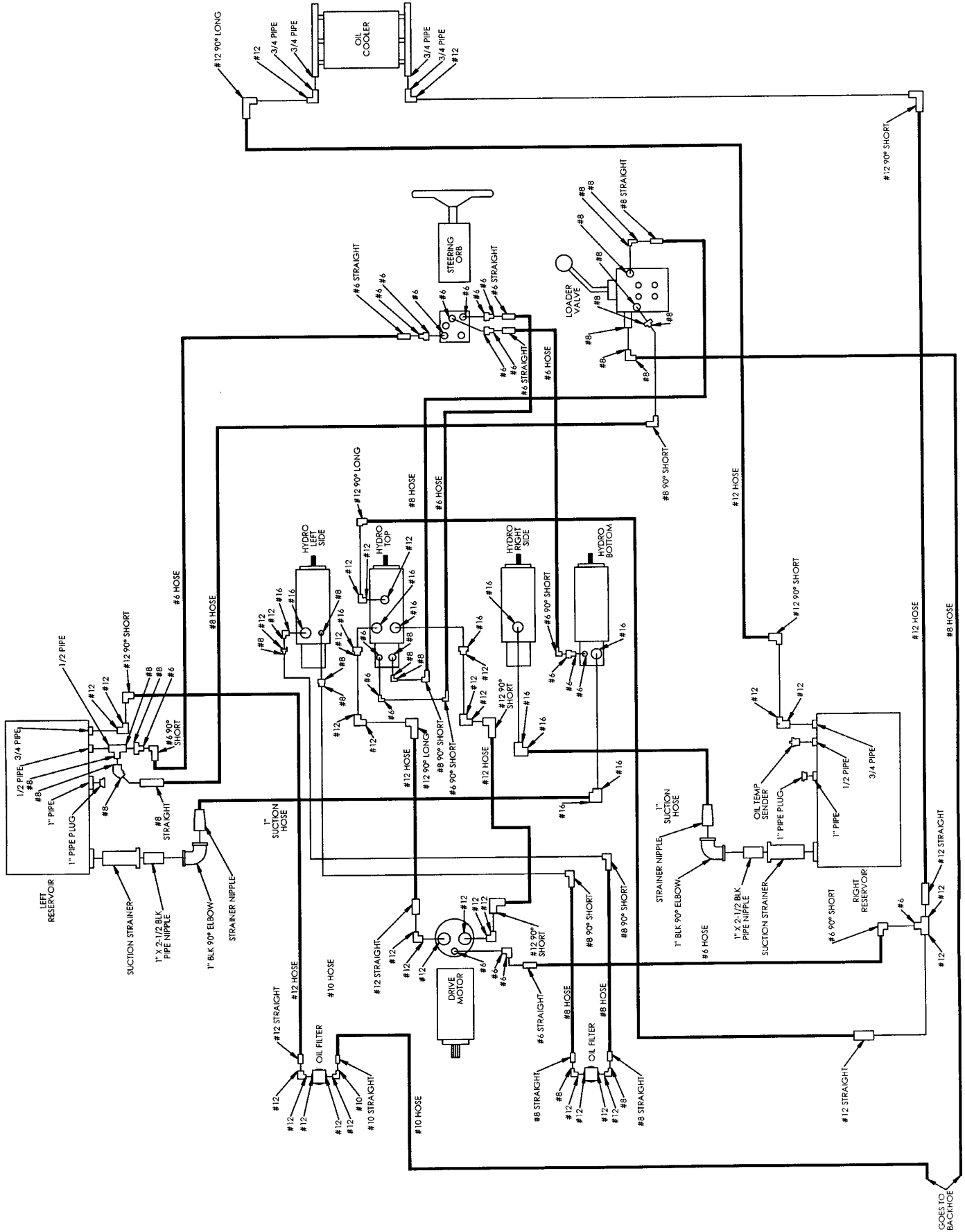

WIRING SCHEMATIC FOR OPTIONAL EQUIPMENT

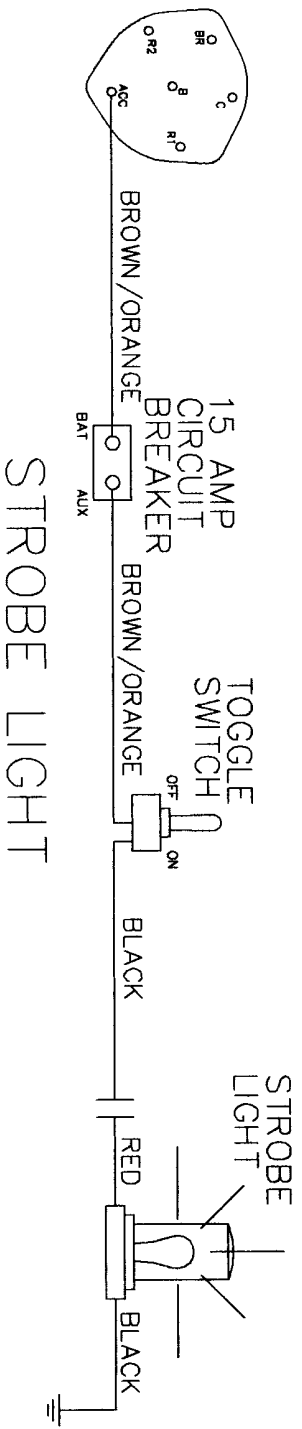
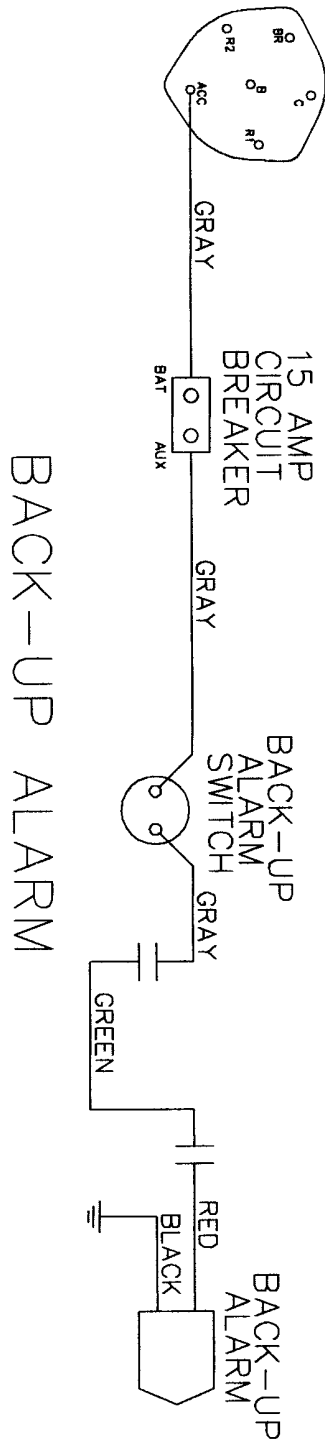
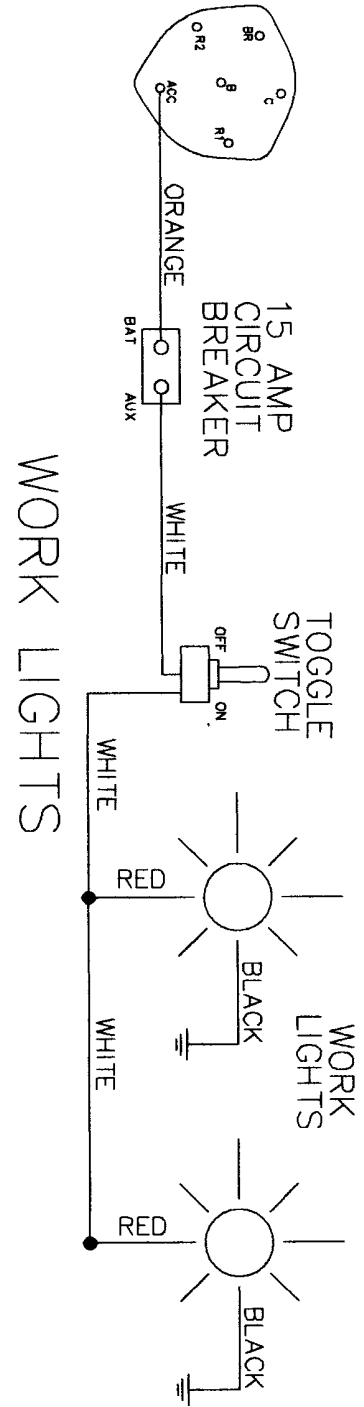

WIRING SCHEMATIC FOR ISUZU 3CD1 ENGINE

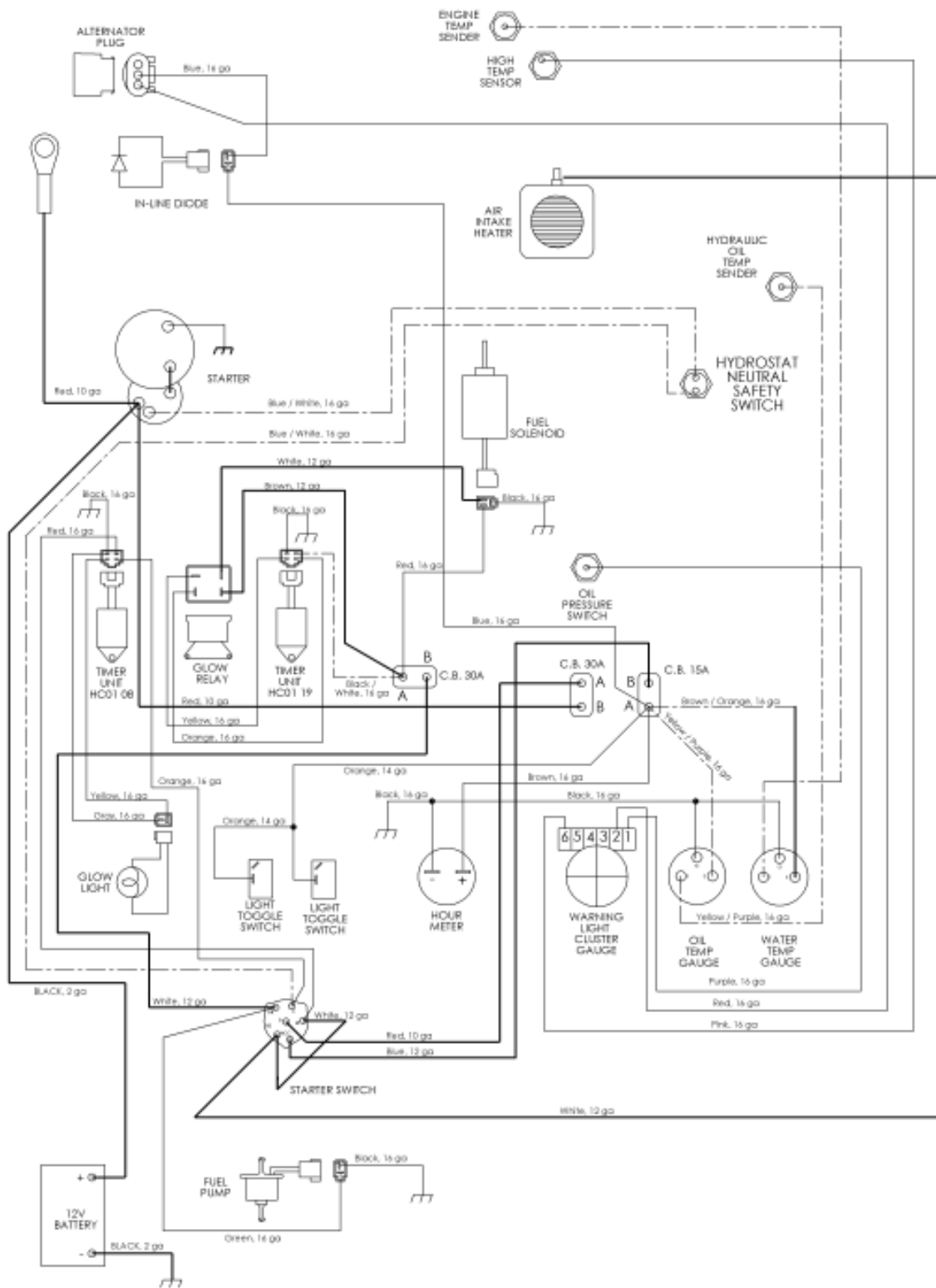

SERVICE INFORMATION

The following information has been provided to assist in making minor adjustments that are part of the routine maintenance of the **TLB 6235**. To remain a safe and trouble free machine, it is recommended to check the following points on a regular basis.

FORWARD/REVERSE PEDAL CREEP ADJUSTMENT

1. Lift the tractor off the ground (all wheels) and support with jackstands.
2. Remove the retaining ring on the ignition switch using a suitable tool such as channel lock pliers.
3. Remove two 1/4" trusshead screws from each side of the steering column cover panel and one 1/4" trusshead screws retaining the top of the panel through the dashboard. Remove the cover panel.
4. Remove two 1/4" trusshead screws retaining the floor plate to the tractor frame and lift off floor plate.
5. Locate the link arm from the pedal to the hydrostat control arm. Remove the bolt from the 3/8" straight yoke in the forward/reverse arm. The hydrostat has an internal centering mechanism and will automatically center itself. Adjust the yoke inward or outward until the bolt can be replaced back through the forward/reverse arm without actuating the hydrostat control arm. Reinstall nut and tighten. (Do not overtighten yoke. Ensure free movement).
6. Reinstall the floor plate with the two truss head screws removed earlier.
7. Reinstall the steering column cover panel using five truss head screws removed earlier.

NOTE: Refer to the **TLB 6235** exploded view drawing on **page 29** to get a better understanding of how the parts are assembled before attempting to make any adjustments. Space is limited in this area and knowing what to look for is quite helpful.

PARK BRAKE ADJUSTMENT

1. Remove the stop screw, on the top of the park brake handle end cap, and turn cap clockwise to increase the brake tension.
2. Replace the stop screw.

If adjustment of the park brake handle does not increase the brake tension, adjustment at the front axle actuator is required. The following information will describe how to adjust the park brake actuator.

1. Using a 7/8" open end wrench, loosen the top lock nut on the brake cable assembly (9). Turn the lower lock nut towards the end of the cable one complete turn of the nut.
2. Tighten the top lock nut and check park brake tension. If tension is too tight, loosen the end cap on the park brake handle to fine tune to the desired amount of tension. If tension is too loose, rework step #1 until desired amount of tension is acquired.*

*Refer to **the** exploded view on the following page for clarification.

Helpful Hint: **Lengthening** the cable will **tighten** the park brake, **shortening** the cable will **loosen** the park brake.

TLB 6235

FORWARD/REVERSE PEDAL CREEP ADJUSTMENT

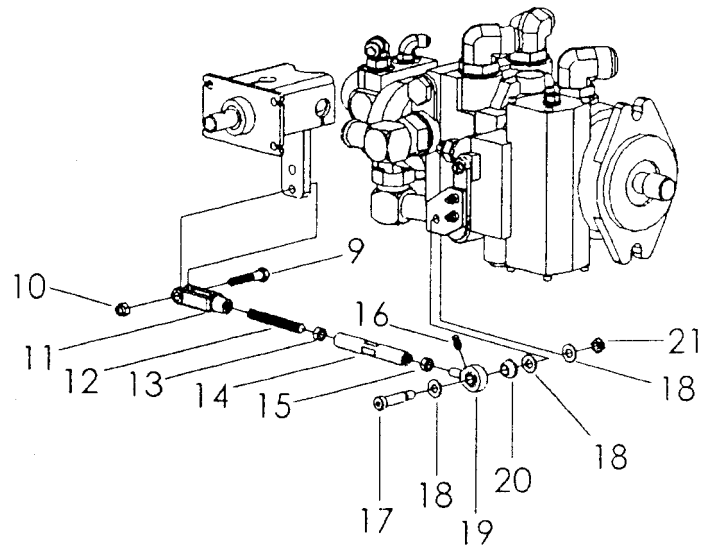

PARK BRAKE ADJUSTMENT

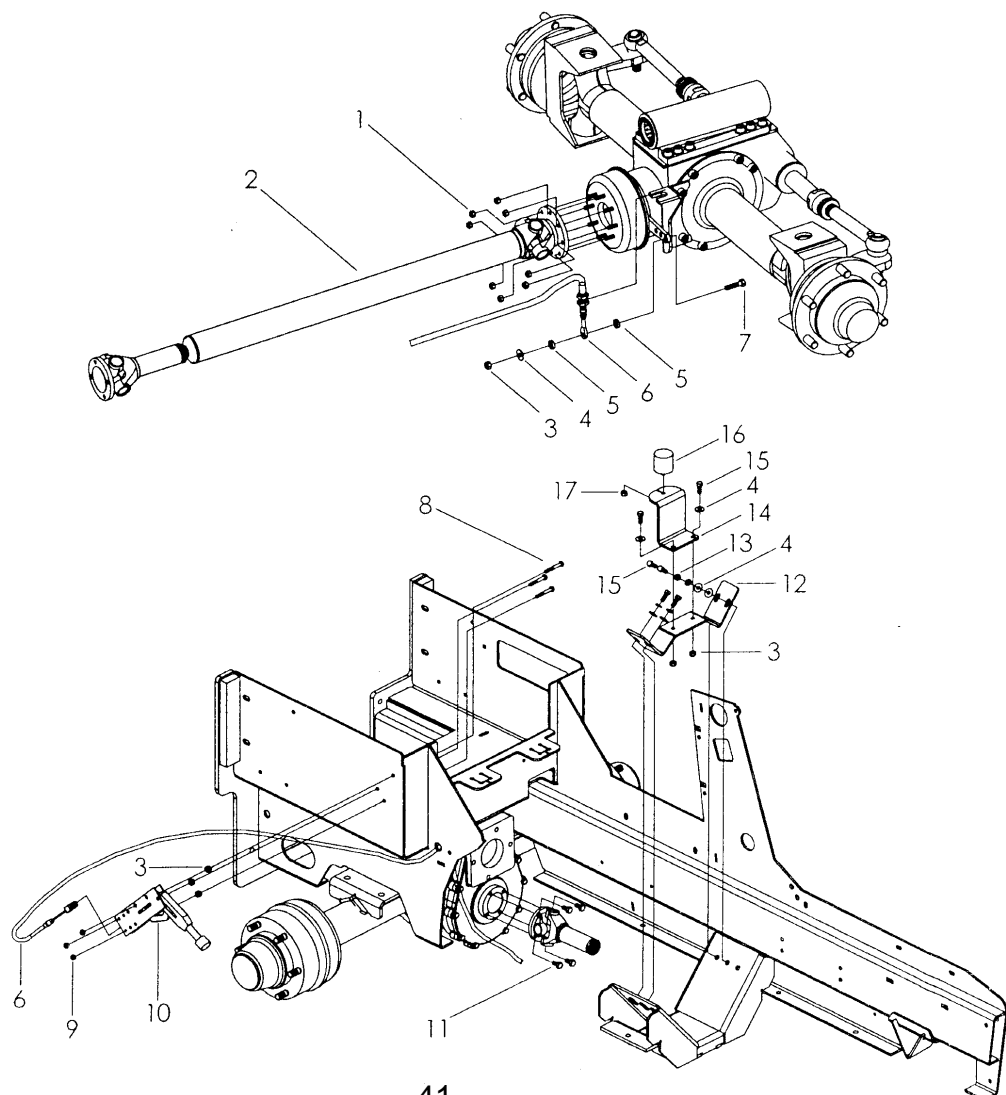

SA/HR Park Brake Testing Instructions

1. Mount tractor on Jack Stands to allow the wheels to spin freely (**See Figure 75**).
2. Start the Engine. Make sure that all 4 wheels rotate in forward and reverse.
3. Turn off the engine.
4. Unhook the quick coupler from the brake that was previously installed (**See Figure 76**).
5. Start the Engine.
6. Actuate the pedal.
7. Make sure that all 4 wheels do NOT rotate in forward or reverse. If the wheels rotate then refer to the installation instructions.
8. Turn off the engine.
9. Reinstall the quick coupler. This will complete the TLB 6235 SA/HR Park Brake Installation. Your Allmand TLB is now ready to be put back into service.



SA/HR Park Brake Towing Instructions

1. Disconnect the quick coupler from the brake (**See Figure 76**).
2. Reconnect the brake to a hydraulic hand pump (**See Figure 77**).
3. Pump the hydraulic hand pump to approximately 200 psi.
4. Start tractor. Make sure the wheels rotate freely, if they do then the tractor is ready for towing.

