

**Note: The Following  
Operator's and Parts Manual  
Applies only to the**

**Allmand™**

**MODEL 75  
BACKHOE**

**(The Model 75 Backhoe is Black in Color)**

Used Exclusively on the  
**Allmand TLB 220**  
and  
**Allmand 225**

Compact Tractor Loader Backhoe Line



For Parts and Updates visit Allmand on the Web at [www.allmand.com](http://www.allmand.com)

# CONTENTS

<b>INTRODUCTION</b>	3
<b>SPECIFICATIONS</b>	4-5
<b>TORQUE CHART</b>	4
<b>SAFETY PRECAUTIONS</b>	6
<b>SAFETY DECALS</b>	7
<b>OPERATION</b>	8-10
Pre-Operation Check List, Operating Directions, Engine Speed	8
Controls, Boom/Swing, Crowd/Bucket	8
Operating Backhoe	9
Placing the Stabilizers	10
Swing Lock, Boom Lock	10
<b>SERVICE</b>	11-13
Cylinder Service	11
Beginning of Season, Hydraulic Hoses, Reservoir	12
Bucket Tooth Points, Lubrication	13
<b>HYDRAULIC TROUBLESHOOTING</b>	14-15
<b>VALVE SERVICE</b>	16-19
<b>PARTS</b>	20-31
Mainframe and Stabilizers	20-21
Swing Post and Swing Cylinders	22
Boom	23
Dipperstick and Bucket	24-25
Cylinders	26-28
Buckets	29
Hydraulic Hoses and Fittings	30-31

# INTRODUCTION

This manual provides operation, maintenance, assembly and parts identification for your new backhoe.

Your backhoe has been designed to give many years of satisfactory service. Successful operation and long life of the backhoe depends on proper maintenance and operation. Please read this manual carefully and follow all instructions. Correct assembly, operation and maintenance will save you much time and expense.



**NOTE:** *This safety alert symbol identifies important safety messages in this manual. Observe and follow all safety messages to prevent personal injury.*

Reference to left-hand and right-hand used in this manual refers to position of operator when seated in the operating position of backhoe.

If at any time you have a service problem with your backhoe or need new parts, contact your local dealer. Your dealer will need your backhoe serial number to give you prompt efficient service.

Parts orders must give complete description, correct part number, total amount required, all necessary serial numbers, method of shipment and shipping address.



\* Serial Number

Date Purchased

\* The serial number is located on left hand side of mainframe.

There are three levels of hazard intensity identified by signal words **DANGER**, **WARNING** and **CAUTION**. The level of hazard intensity is identified by the following definitions.



**DANGER** - Immediate hazards which will result in severe injury or death.



**WARNING** - Hazards or unsafe practices which could result in minor personal injury or property damage.



**CAUTION** - Hazards or unsafe practices which could result in minor personal injury or property damage.



THIS SAFETY SYMBOL MEANS

**ATTENTION!**

**BECOME ALERT!**

**YOUR SAFETY IS INVOLVED!**

# SPECIFICATIONS

Specifications may vary depending on tire size and bucket used and are subject to change without notification. Tractor must be equipped with ROPS and seat belt that will provide greater safety.

## GENERAL DATA

A	Digging Depth (two foot flat bottom)	90"(7'6")
B	Reach from center line of Swing Pivot	119"(9'11")
C	Loading Height* (bucket at 60°)	66"(5'6")
D	Load Reach*	41"(3'5")
E	Maximum Leveling Angle*	7.6°
F	Swing Arc	180°
G	Transport Height (maximum)	75"(6'3")
H	Transport Overhang	46"(3'10")
I	Bucket Rotation	171°
J	Stabilizer Spread, down position	78"(6'6")
K	Stabilizer Spread, up position	53"(4'5")
	Shipping Weight (less bucket)	855 lbs.
	Bucket Digging Force	2675 lbs.
	Dipperstick Digging Force	2105 lbs.
	Operating Pressure	2000 PSI
L	Straight Wall Depth	49"(4'1")
M	Digging Depth—8' Flat Bottom	68"(5'8")
•	Per SAE J49	

## BUCKET DATA

BUCKET WIDTH	SAE STRUCK CAPACITY	SAE HEAPED CAPACITY	SHIPPING WEIGHT
9"	0.73 cu.ft.	0.87 cu.ft.	46 lbs.
12" H.D.	1.01 cu. ft.	1.24 cu. ft.	72 lbs.
16" H.D.	1.38 cu. ft.	1.76 cu. ft.	82 lbs.
18" H.D.	1.56 cu. ft.	2.02 cu. ft.	93 lbs.

CYLINDER DATA	PISTON DIA.	STROKE	RETRACTED LENGTH	EXTENDED LENGTH	ROD DIA.
<b>Boom</b>	2.75"	16.75"	24.25"	41.00"	1.50"
<b>Dipperstick</b>	2.75"	16.75"	24.25"	41.00"	1.50"
<b>Bucket</b>	2.25"	16.75"	24.25"	41.00"	1.375"
<b>Swing</b>	2.25"	6.84"	5.52"	12.47"	1.375"

## GENERAL TORQUE SPECIFICATIONS

USE THE FOLLOWING TORQUES WHEN SPECIAL TORQUES ARE NOT GIVEN

AMERICAN STANDARD CAP SCREWS						METRIC CAP SCREWS													
SAE Grade		5				8				Metric Class		8.8				10.9			
Cap Screw		TORQUE				TORQUE				Cap Screw		TORQUE				TORQUE			
Size	FT-LBS	MIN		MAX		Size	FT-LBS	MIN		MAX		Size	FT-LBS	MIN		MAX			
Inches	MIN	MAX	MIN	MAX	MIN	MAX	MIN	MAX	Millimeters	MIN	MAX	MIN	MAX	MIN	MAX	MIN	MAX		
1/4-20	6.25	7.25	8.5	10	8.25	9.5	11	13	M6x100	6	8	8	11	9	11	12	15		
1/4-28	8	9	11	12	10.5	12	14	16	M8 x 1.25	16	20	215	27	23	27	31	36.5		
5/16 - 18	14	15	19	20	18.5	20	25	27	M10 x 1.50	29	35	39	47	42	52	57	70		
5/16 - 24	17.5	19	23	26	23	25	31	34	M12 x 1.75	52	62	70	84	75	91	102	123		
3/8 - 16	26	28	35	38	35	37	47.5	50	M14 x 2.00	85	103	115	139	120	146	163	198		
3/8 - 24	31	34	42	46	41	45	55.5	61	M16 x 2.50	130	158	176	214	176	216	238	293		
7/16 - 14	41	45	55.5	61	55	60	74.5	81	M18 x 2.50	172	210	233	284	240	294	325	398		
7/16 - 20	51	55	69	74.5	68	75	92	102	M20 x 2.50	247	301	335	408	343	426	465	577		
1/2 - 13	65	72	88	97.5	86	96	116	130	M22 x 2.50	332	404	450	547	472	576	639	780		
1/2 - 20	76	84	103	114	102	112	138	152	MM24 x 3.00	423	517	573	700	599	732	812	992		
9/16 - 12	95	105	129	142	127	140	172	190	M27 x 3.00	637	779	863	1055	898	1098	1217	1488		
9/16 - 18	111	123	150	167	148	164	200	222	M30 x 3.00	872	1066	1181	1444	1224	1496	1658	2027		
5/8 - 11	126	139	171	188	168	185	228	251											
5/8 - 18	152	168	206	228	203	224	275	304											
3/4 - 10	238	262	322	355	318	350	431	474											
3/4 - 16	274	305	371	409	365	402	495	544											
7/8 - 9	350	396	474	523	466	515	631	698											
7/8 - 14	407	448	551	607	543	597	736	809											
1 - 8	537	592	728	802	716	790	970	1070											
1 - 14	670	740	908	1003	894	987	1211	1337											

NOTE: These values apply to fasteners as received from the supplier, dry or when lubricated with normal engine oil. They do not apply if special graphite or molydisulphide greases or other extreme pressure lubricants are used.

# SPECIFICATIONS

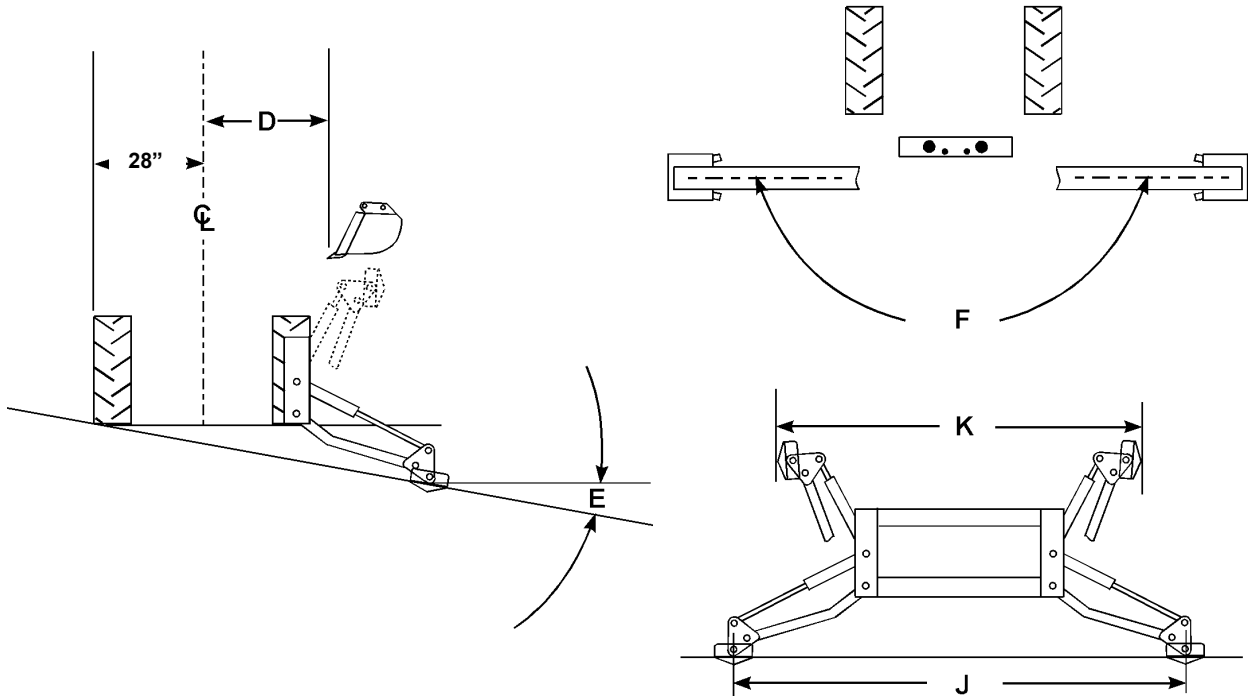
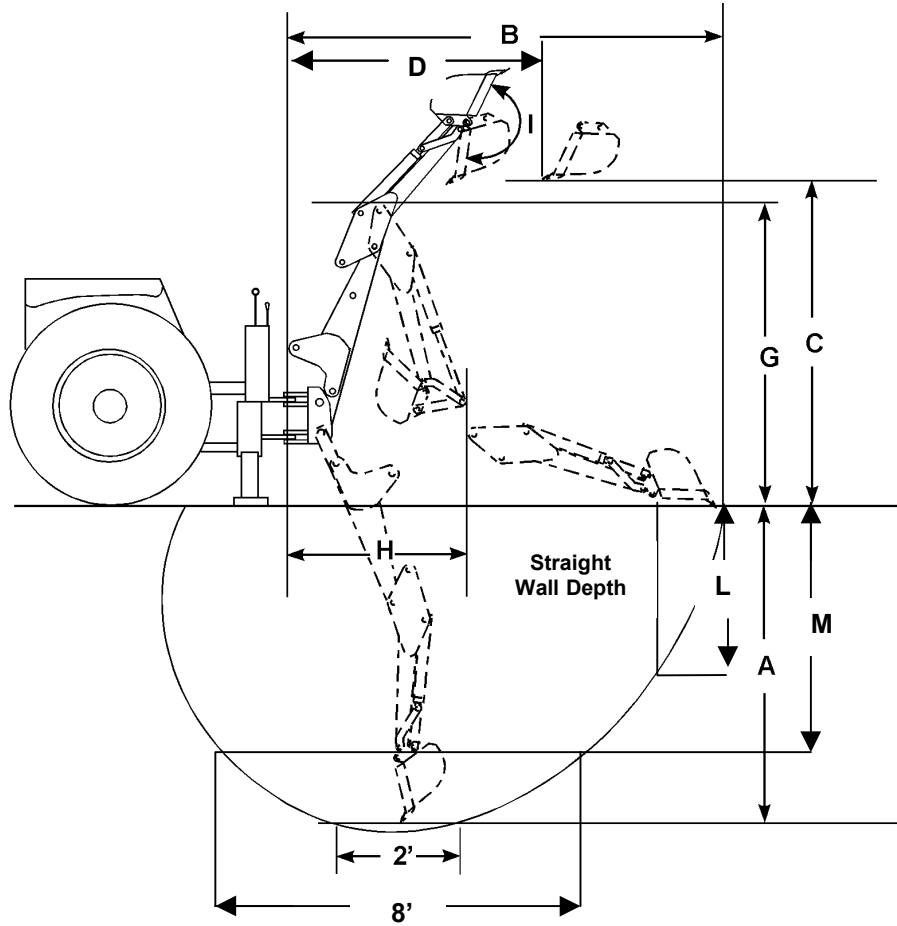

# SAFETY PRECAUTIONS



*Safety of the operator was a prime consideration in the design of this backhoe. Proper shielding convenient controls, simple adjustments and other safety features have been built into this backhoe.*

*Accidents can be avoided if the following safety rules are observed:*

## PREPARATION

Do not operate backhoe unless it is rigidly attached to the tractor.  
Know your controls. Read this operator's manual and the manual provided with your tractor. Learn how to stop the tractor; the engine; and the backhoe quickly in an emergency.  
Provide adequate front end weight to counter balance the backhoe at all times.  
Be sure the area is clear of underground utilities or other hazards.  
Position a barricade around the work area.  
Keep all bystanders a safe distance away.

## OPERATION

Never allow anyone to operate the backhoe who is not familiar with safe operating practices.  
Do not attempt to enter operator's platform by using stabilizers as a step.  
Operate from the backhoe operator's seat only.  
Allow only one person to operate the backhoe at a time.  
Never dig with backhoe unless stabilizers are properly set.  
Do not dig under stabilizers or tractor with backhoe. Soft ground or sandy soil can cause cave-ins.  
Always swing bucket uphill to dump when on a hillside. Keep loaded bucket low.  
Set brakes and lock wheels when operating on hills and banks to avoid dangerous run-away.  
Watch for overhead wires. Do not touch wires with any part of backhoe.

Never allow a person to work under a raised bucket.

Do not use bucket as a battering ram.

Whenever you see this symbol



Always lower bucket to ground when not digging.  
Never leave tractor unattended with engine running.

## TRANSPORTATION

Do not drive tractor near the edge of a ditch or excavation.  
Always use accessory lights when transporting on a road or highway to warn operators of other vehicles.  
Check your local government regulations.

## ADJUSTMENTS AND INSPECTION

Check hardware that attach backhoe to tractor and all pivot pins for tightness several times daily. Replace any parts that are bent, broken or missing.  
Do not oil, grease or adjust backhoe while it is in motion.  
Do not change any backhoe relief valve settings. They are factory set for best backhoe performance and safety.



**CAUTION:** *Escaping hydraulic fluid under pressure can penetrate skin causing serious personal injury.*

- **DO NOT** use your hand to check for leaks. Use a piece of cardboard or paper to search for leaks.
- Stop engine and relieve pressure before connecting or disconnecting hydraulic lines.
- Tighten all connections before starting engine or pressurizing lines.
- 

***If any fluid is injected into skin, obtain medical attention immediately or gangrene may result.***

Be sure to relieve all pressure before disconnecting lines. Be sure all connections are tight and that lines, pipes and hoses are not damaged before applying pressure to the system.  
Do not remove any guards on backhoe or tractor.

It means: **ATTENTION!**

**BECOME ALERT!**

**YOUR SAFETY IS INVOLVED!**

# SAFETY DECALS

**NOTE:** Safety decal location is listed below each decal. Replace decal if damaged or illegible. Replacement decals are available from your dealer.



DECAL P.N. 44896  
Location: Back of Mainframe

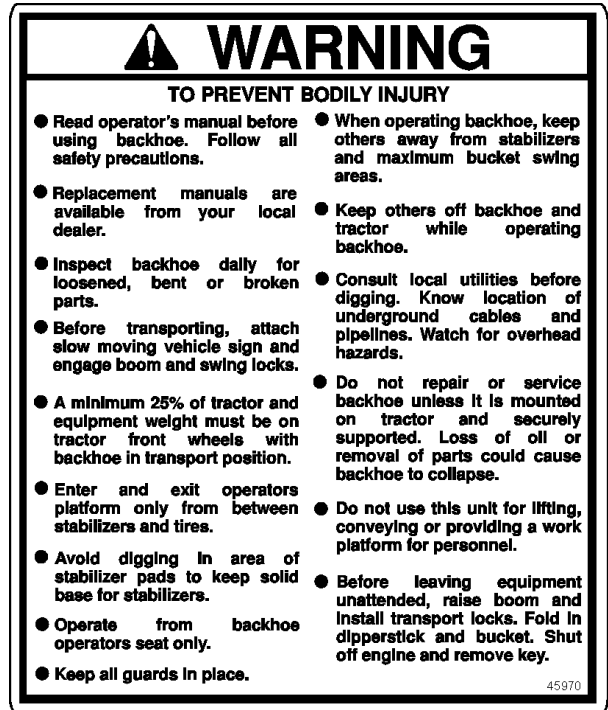

DECAL P.N. 45970  
Location: Both Sides of Mainframe



DECAL P.N. 44895  
Location: Both sides of Mainframe



DECAL P.N. 44897  
Location: Left and Right Stabilizer Cylinders

DECAL P.N. 44907  
Location: Top of Valve Cover



# OPERATION



**CAUTION:** To avoid possible injury, observe the following safety rules **BEFORE OPERATING** backhoe.

- Be sure area is clear of underground utilities or other hazards.
- Position a barricade around work area.
- Keep bystanders a safe distance away.

## PRE-OPERATION CHECKLIST

This backhoe is designed for safety, durability and operator convenience. To insure satisfactory performance complete the following check list and make all necessary adjustments before initial operation.

1. All safety shields must be in place.
2. Safety and operation decals must be in place, undamaged and clean.
3. Hydraulic hookup must be correct and all connections tight.
4. All hardware which attach backhoe to tractor must be properly torqued and in place.
5. Tractor must be in proper operating condition.
6. Lubricate backhoe, see “**SERVICE**”.
7. Controls must operate properly. See “**GENERAL OPERATION**”.
8. Cycle all cylinders slowly to purge air from hydraulic system.

## OPERATING DIRECTIONS

The terms right, left, front and back shall be from the position of the operator when seated in the operating position on the backhoe.

### ENGINE SPEED

Speed at which backhoe operates is dependent on tractor RPM. Use a moderate engine speed to start and increase it as your experience permits.

## CONTROLS

The backhoe has two major control levers, Boom/Swing and Crowd/Bucket. These controls are located on the control panel directly ahead of the operator. The stabilizer control levers are located between the two major control levers.

### BOOM/SWING

Push lever forward, boom moves down, away from operator. Pull lever back, boom moves up, toward operator.

Move lever to left, backhoe swings left. Move lever to right, backhoe swings right.

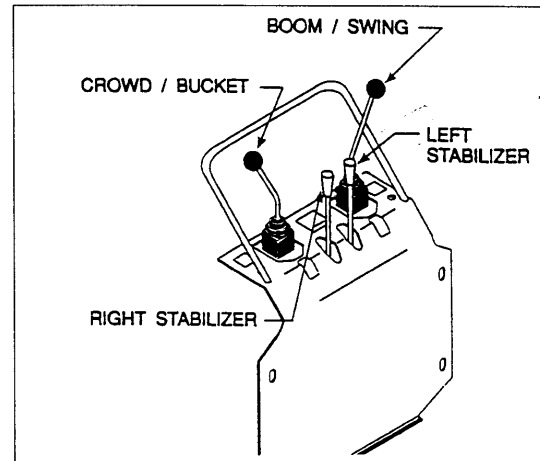

By moving lever to one of the intermediate positions, boom can be swung left or right at the same time as it is being raised or lowered, performing two operations simultaneously.

- Swing left and lower boom by moving control lever forward and to the left.
- Swing left and raise boom by moving control lever back and to the left.
- Swing right and lower boom by moving control lever forward and to the right.
- Swing right and raise boom by moving control lever back and to the right.

## CROWD/BUCKET

- Push lever forward, dipperstick moves away from operator. Pull lever back, dipperstick moves toward operator.
- Move lever to left, bucket curls in. Move lever right, bucket extends out.
- By moving lever to one of the intermediate positions, dipperstick can be extended or retracted at the same time as bucket is being loaded or dumped.
- Move dipperstick away and extend bucket by moving lever forward and to the right.
- Move dipperstick toward operator and curl bucket by moving lever back and to the left.
- Move dipperstick away and extend (dump) bucket by moving lever forward and to the right.
- Move dipperstick toward operator and extend bucket by moving lever back and to the right.

The two operations of the boom and swing lever combined with the two operations performed by bucket and dipperstick control lever provide four simultaneous operations from the two levers. Oil flow will go to operation which requires the least pressure. The ability to feather valve spools and balance pressure comes with experience resulting in reduced cycle times.



# OPERATION

## LEFTHANDSTABILIZER

Push lever forward, left hand stabilizer lowers. Pull lever back, left hand stabilizer raises.

## RIGHTHANDSTABILIZER

Push lever forward, right hand stabilizer lowers. Pull lever back, right hand stabilizer raises.



### OPERATINGBACKHOE

**CAUTION:** To avoid possible injury, observe the following safety rules **WHEN OPERATING** backhoe.

- Operate from backhoe operators seat only.
- Lower stabilizers until weight of tractor is supported by stabilizers. Do not lift tractor tires off ground.
- Do not dig near stabilizers.
- Do not attempt to raise tractor off ground or move tractor forward or backward using backhoe dipperstick or bucket.
- Do not lose stability by swinging bucket downhill when positioned on a slope.

It is not difficult to become an efficient operator. Control operating decals are located in front of control levers. Study these decals. They will assist you in becoming familiar with the controls.

Smooth, light handling of controls will result in the most efficient backhoe operation.

Operate backhoe control levers to become familiar with their speed and movements. Engine RPM will determine speed of cylinder operation.

Swing boom several times to practice controlling the speed of swing. Do not operate swing more than 45 degrees each way for the first few times. Gradually increase the arc.

Best results are obtained by digging near center of swing arc so material can be dumped on either side.

As operator becomes more familiar with operation of backhoe, it will be common practice to operate two controls at one time. For example with bucket extended and dipperstick extended, the lift control and crowd control can be operated together to bring bucket toward operator with down pressure on it. As dipperstick approaches operator, the crowd and bucket controls can be operated together to close bucket and trap material. At end of stroke, lift and crowd controls are operated to

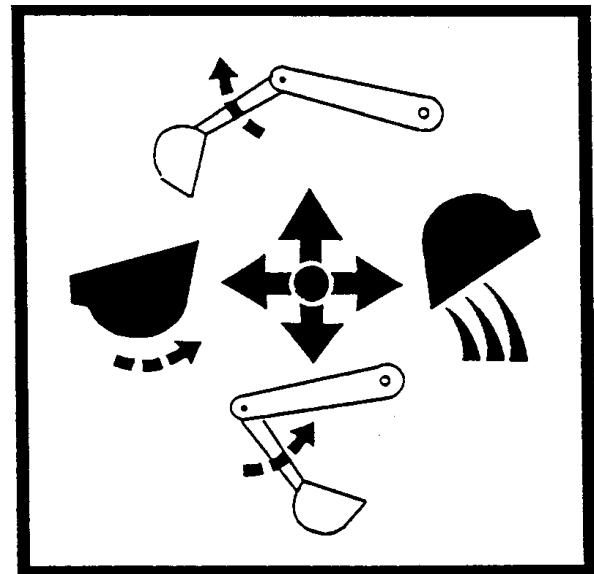
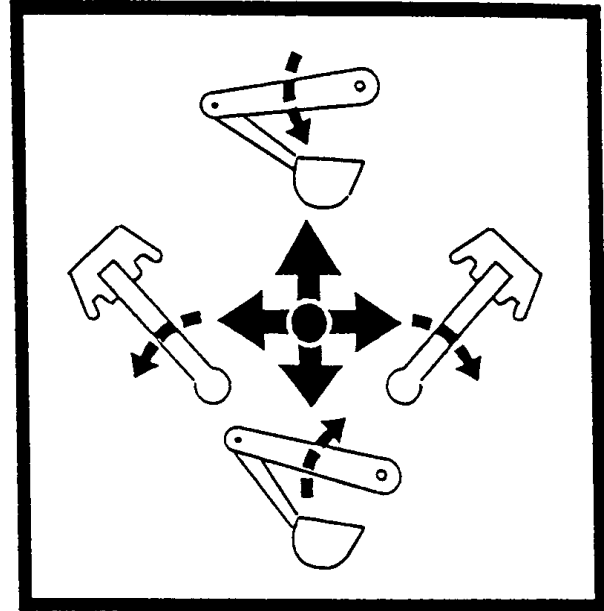

move load up and away from operator to save time in clearing excavation.

This dual operation of controls will speed and simplify digging operation. Normally two or more movements will not be equal or even simultaneous but as pressure within the cylinders, and as resistance of an operating member of backhoe lessens, it will begin to move. It is balancing the force of one member against another.

**NOTE:** Actuating bucket is the key to powerful digging. Operating the crowd and bucket controls simultaneously will insure a full bucket and prevent wasted motion and time.

# OPERATION

## MOUNTING AND DISMOUNTING BUCKETS

### Standard Bucket:

Mount standard buckets using 1 x 6-5/8 anti rotation pins (1), 3/8 x 1-1/8 cap screws (2) 3/8 jam nuts (3), 3/8 flat washers (4) and 3/7 lock nuts (5).

**NOTE:** *Wrench flats of jam nut should fit into hole in pin ear.*

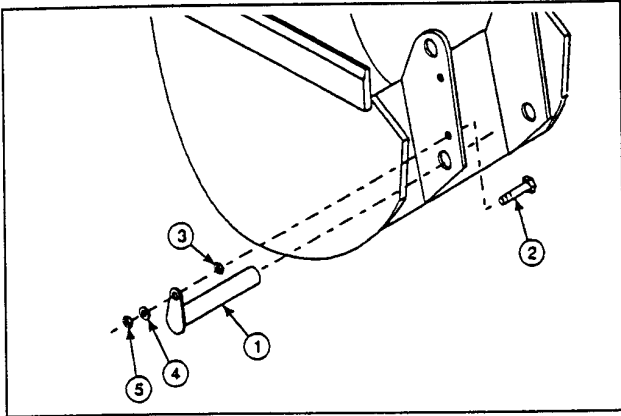

## PLACING THE STABILIZERS

Set the stabilizers to remove weight from the rear wheels. Rear wheels are to remain touching the ground as this provides for the widest stabilizer stance and lowest center of gravity

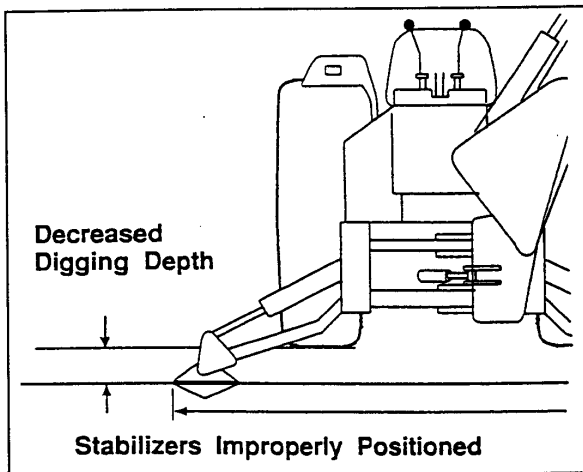

Raising the wheels off the ground will not only reduce stability and digging depth, but impair performance and impose unnecessary stress on the backhoe and tractor.

## SWING LOCK

Use swing lock when transporting or dismounting backhoe. Position boom straight back and drop pin through holes in swing frame and mainframe. Store pin in hole provided on mainframe.

## BOOM LOCK

Use boom lock when transporting backhoe.

1. Completely raise boom and lower dipperstick.
2. Secure boom using boom lock pin and hair pin clip.

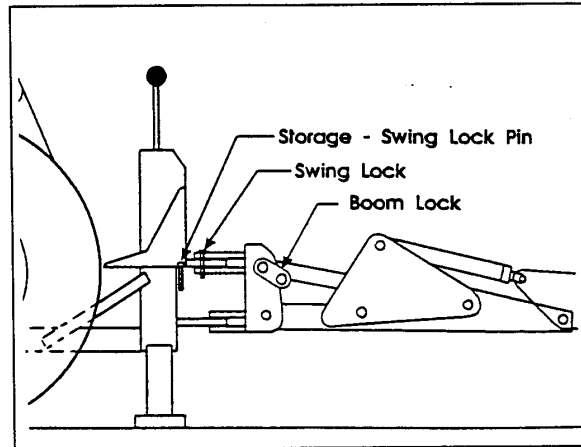

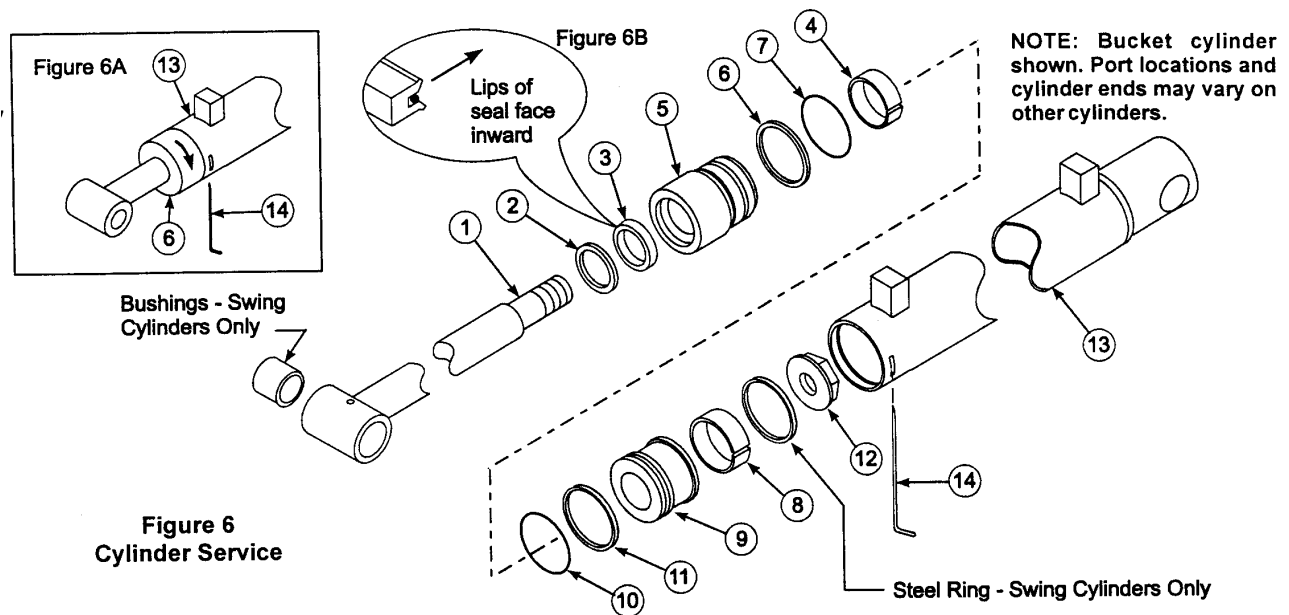

**Figure 6  
Cylinder Service**

## CYLINDER SERVICE

Cylinders are designed to be reliable and easy to service. If a cylinder should malfunction during warranty period, return complete cylinder assembly, without disassembling, to your authorized service department or contact your authorized service department for instructions. Unauthorized disassembly of a cylinder in warranty period will **VOID WARRANTY**.

*Following is an outline procedure for disassembling and reassembling cylinders.*

### CYLINDER

1. Hold cylinder tube (13 figure 6A) stationary and pull wire ring (14) out through slot. Rotate head (6) to ease disassembly.
2. Pull shaft (1), with all assembled parts, out of cylinder tube.

**NOTE:** Resistance will be felt until piston seal (10) slides over wire retaining ring groove. Seal is usually damaged when cylinder is disassembled

3. Remove lock nut (12) from end of shaft and slide piston (9) and cylinder head (6) off shaft.
4. Remove piston wear ring (11), piston seal (10), and o-ring (8) from outside grooves on piston (Swing cylinders have additional steel ring between piston and nut).
5. Remove wiper seal (2), rod seal (3) and wear ring (7) from inside of cylinder head and o-ring (5) with backup washer (4) from groove on outside of head.
6. Clean all parts including cylinder tube, in a suitable cleaning solvent, and then use air pressure to blow any dirt or excess solvent from all parts.
7. Examine all parts for wear or damage and replace, if necessary.

## CYLINDER ASSEMBLY

**NOTE:** Be careful not to damage seals and o-rings on edges or holes in cylinder tube. Inspect and remove burrs and sharp edges if necessary before reassembly.

1. Place rod seal (3) into groove inside cylinder head.

**NOTE:** Lips of seal (3) must face inward and seal must be firmly seated in groove (Figure 6B). For easier installation, place seal (3) in 120°F water to warm seal.

2. Install wiper seal (2) with lip of seal facing out and flush with top of cylinder head. Install wear ring (7) inside other end of head.
3. Place o-ring (5) with back-up washer (4) in groove on outside of head. Back-up washer must be on rod side.
4. Remove sharp edges on outer edge of threaded end of shaft (1). Lubricate wiper seal (2) and rod seal (3) in head and carefully slide head onto shaft.
5. Place o-ring (8), piston seal (10) and piston wear ring (11) in grooves on outside of piston.

**NOTE:** For easier installation, place piston seal (10) in 120°F water to warm seal.

6. Slide piston onto threaded end of shaft and install lock nut (12). Swing, bucket and stabilizer cylinders, tighten lock nut (12) to 300 ft. lbs. Lift and dipperstick cylinders tighten lock nut (12) to 375 ft. lbs. on lift cylinders.
7. Lubricate piston wear ring (11) and piston seal (10) on piston, o-ring (5) and backup washer (4) on head and inside of cylinder tube (13), then carefully slide piston and head into cylinder tube.

Insert wire retaining ring (14) into slot in cylinder tube (13). Apply pressure to wire ring to thread it into groove while turning cylinder head.

# SERVICE



**CAUTION:** To avoid possible injury, observe the following safety rules when servicing backhoe.

- Do not oil, grease or adjust backhoe while it is in motion.
- Do not change any backhoe relief valve settings. Relief valve settings are factory set for best backhoe performance and safety.
- Escaping fluid under pressure can have sufficient force to penetrate the skin and cause serious injury. Be sure to relieve all pressure before disconnecting lines. Be sure all connections are tight and that lines, pipes and hoses are not damaged before applying pressure to the system.
- Fluid escaping from a very small hole can be almost invisible. Use a piece of cardboard or wood - not your hands - to search for suspected leaks.
- See a doctor at once if injured by escaping fluid. Serious infection or reaction can develop if proper medical treatment is not administered immediately.
- Protect your eyes - wear safety glasses. Guard against injury when driving connecting pins or performing any repair in which particles can chip from work piece or striking tool.

## BEGINNING OF SEASON

- Remove all protective covering. Remove excessive grease from cylinder rods if unit has been in long term storage.
- Check hydraulic hoses for deterioration and replace if necessary. Caution hydraulic hoses may be under pressure. Make sure pressure has been relieved before removing hoses.
- Lubricate all grease fittings and oil handle linkage.
- Clean and inspect all safety and operation decals. Replace missing or damaged decals.
- Replace oil filter.

- Fill hydraulic fluid to proper level.
- Tighten all loose bolts, nuts and set screws (See torque chart page 4).
- Sharpen or replace worn bucket teeth.
- Operate backhoe slowly for a short time before placing unit under full load.
- Fully cycle backhoe through all movements several times to purge air from the system.

## HYDRAULIC HOSES



**WARNING:** *Escaping hydraulic fluid under pressure can penetrate skin causing serious injury.*

- **DO NOT** use your hand to check for leaks. Use a piece of cardboard or paper to search for leaks.
- Stop engine and relieve pressure before connecting or disconnecting lines.
- Tighten all connections before starting engine or pressurizing lines.

Oil leaks on the suction side will draw air into the system, causing oil in reservoir to appear foamy.

When tightening connections always use two wrenches.

**IMPORTANT:** *Do not over tighten fittings. Make them just tight enough to eliminate leaks.*

**NOTE:** *Apply sealant only to all tapered threads unless coupled with swivel adapters. When using teflon tape, wrap tape clockwise (as viewed from end) and wrap tape only twice. Keep sealant away from first two threads of tapered end to prevent contamination of hydraulic fluid. Do not use sealant on o-ring or flare adapter threads.*

Hoses on backhoe are very severely worked and will fail in time. Examine them regularly and replace any that show signs of failure. Pay careful attention to routing of hoses so they can move freely, without kinking and cannot be pinched or cut by any part of backhoe.

# SERVICE

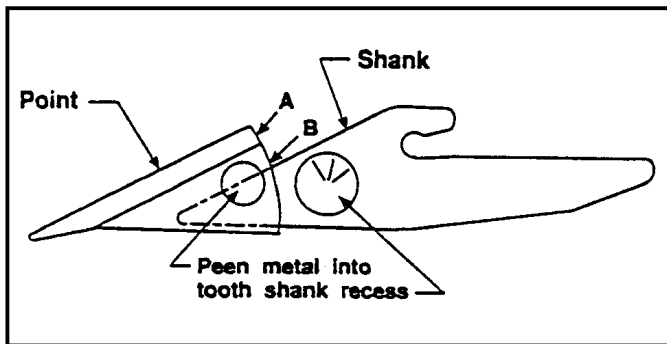

## BUCKET TOOTH POINTS

Bucket tooth points are self sharpening and will require little attention. However, points can be replaced when they become badly worn or broken.

Remove point from welded tooth shank by hammering at "A" on tooth point or by driving a chisel at "B", just between tooth point box section and tooth shank. Install new point and anchor it to shank by peening at location shown.

If a tooth shank breaks off, becoming lost or damaged so that it can not hold a tooth point, a new shank should be welded to bucket.

## TIGHTENING NUTS AND BOLTS

Periodically check to be sure all bolts and nuts are tight (See torque chart page 4).

Check all pivot pins for cotter pins, washers and retainers. If any are missing replace them.

## LUBRICATION

Economical and efficient operation of backhoe is dependent upon regular and proper lubrication of all moving parts with a quality lubricant.

All parts provided with grease fittings should be lubricated with a good quality chassis lube type grease. If any grease fittings are missing, replace them immediately. Clean all fittings thoroughly before using grease.

ITEM NO.	LOCATION DESCRIPTION	QTY. TOTAL
1	Rod, Stabilizer Cylinders	2
2	Rod, Swing Cylinders	2
3	Base, Stabilizer Cylinders	2
4	Base, Boom Cylinder	1
5	Rod, Boom Cylinder	1
6	Base, Crowd Cylinder	1
7	Rod, Crowd Cylinder	1
8	Boom-Dipperstick Pivot	1
9	Base, Bucket Cylinder	1
10	Rod, Bucket Cylinder	1
11	Bucket- 4-Bar Link	1
12	Dipperstick-Bucket Pivot	1
13	Swing Post	2
14	Boom to Swing Frame	1
15	Upper Swing Cylinder Bearing	2
16	Lower Swing Cylinder Bearing	2
17	Dipper- 4-Bar Link	1

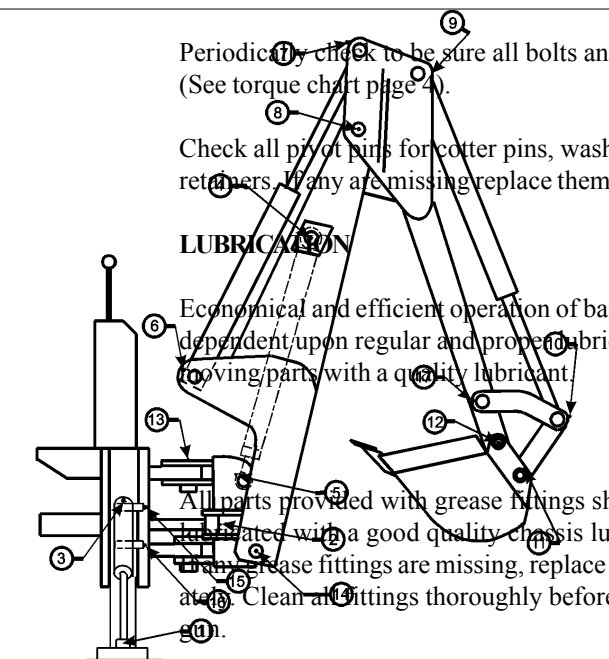

Lubricate all 23 grease fittings at least twice daily (See chart for locations), once at the beginning of operation and again approximately half way through the work day. Grease hourly any joints that operate in water.

Control valve handle linkage should be oiled with SAE 30 oil.

**IMPORTANT: Avoid excessive greasing. Dirt collects on exposed grease and greatly increases wear. After greasing wipe off excess grease from fittings**



# HYDRAULIC TROUBLE SHOOTING

POSSIBLE CAUSE		CORRECTIVE ACTION
17	Oil leakage past spool seal into spool cap	If spool cap contains oil, replace spool seal o-ring. If o-ring retainer is "belled" check for restriction from "out" port reservoir. See item 30.
18	Broken return springs	Replace springs. See item 30.
19	Bent spool.	Return for factory repair or replace with new spool section. See item 30.
20	Foreign particles.	Clean system and valve.
21	Misalignment of control handle linkage or spool bonnet.	Check linkage for binding condition; loosen bonnet, operate valve to realign, and retighten.
22	Spool not moved to full stroke.	Spool travel should be 5/16" either way or 5/8" total. See item 30.
23	Relief valve setting in control valve too low or defective.	Clean or overhaul relief valve or replace cartridge. Refer to VALVE SERVICE section for proper PSI settings
24	Overload relief valve in control valve stuck open or malfunctioning.	Clean relief. Do not disturb pressure setting or replace cartridge.
25	Worn control valve.	Replace control valve.
26	Check poppet in control valve not holding.	Clean check poppet(s) carefully. Ensure free movement and proper seating or replace check poppet(s). See item 30.
27	Damaged or worn spool seals.	Replace spool end seals.
28	Check ball in anti-cavitation is stuck or not seated properly.	Clean anti-cavitation valve carefully. Assure that checks move freely and seat properly or replace cartridge. See item 30.
29	Valve cap and center return mechanism binding.	Loosen screws holding cap on valve (ref. Item#2 P.22). Operate valve spool and retighten screws.

**30.** This valve is a precision device and is not intended for extensive field adjustment or repair. Field replacement parts are limited to seal kits, cartridges, valve sections and tie rod ends. Beyond replacement of these parts, opening of check cavities and certain relief valve cavities to examine for trapped dirt, or resetting main relief valve with the use of a good pressure gauge, valve should be returned for service.

Dirt and shreds of packing material are the usual causes of valve malfunction. Be sure that oil supply is kept clean. Use only factory supplied packings in cylinder repair. Fittings and hoses must be clean before being removed. Pages 20 & 21 explain proper valve repair procedure. Pages 22 & 23 illustrate valve and lists repair parts.

**NOTE: Pay close attention to all caution warning notes so valve will not have to be returned to manufacturer for reconditioning.**

Troubleshooting guide is designed to help qualified individuals, with valve service training, correct minor problems which may develop. If valve is under warranty do not attempt disassembly for repairs. Contact your authorized dealer.

# VALVE SERVICE

## REPLACING SECTIONS

For clarification, the inlet cover [cover containing main relief cartridge (18) ] will be called the left end of the valve assembly.

Reassemble valve on a flat surface to insure proper section alignment.

1. Remove handle assembly from section being removed.
2. Remove valve from backhoe.
3. Thoroughly clean valve assembly.
4. Before disassembly, mark each section numerically to avoid incorrect reassembly.
5. Remove four hex nuts and lock washers from right (outlet cover) end of valve.
6. Slide outlet cover and each section off tie rods.
7. Replace sections as needed. Reassemble valve.

**NOTE:** Refer to "Replacing Section Seals" if seals need to be replaced.



**WARNING:** Do not prelube O-ring section seals prior to installation. Compression of lubricants can distort valve causing spool binding.

8. Torque stud nuts evenly to 15ft. Lbs .



**CAUTION:** If stud nuts are not tightened to proper torque, valve spools may bind or stick, or cause O-ring seals to extrude.

9. Reinstall handle assembly. Use locite 242 (blue) on all screws.

## REPLACING SECTION SEALS

1. Disassemble valve as described in previous section.
2. Remove old O-ring section seals. Be careful not to scratch or otherwise damage sealing surface areas.
3. Thoroughly clean O-ring counter bores and surfaces of each valve section.
4. Place valve assembly on a flat surface for reassembly.
5. Replace four O-ring seals. Seal Kit contains the number of section seals required for one work section/inlet cover.
6. Replace work sections on assembly studs in reverse order in which they were removed. O-ring counter bores (with O-rings in place) should be to your right (downstream side of section) with inlet cover on your left.

**NOTE:** Use care when sliding work sections on tie rods to avoid dislodging O-rings.

1. When all work sections and outlet cover are positioned on the assembly studs, replace lock washers and nuts.
2. Torque stud nuts evenly 15ft. Lbs.

## SPOOL SEAL REMOVAL

1. Remove handle assembly and clevis pin from spool.
2. Remove bonnet and spool positioner assembly from rear of the work section.
3. Carefully slide spool out of valve housing.
4. Remove old spool seals. Be careful not to scratch or damage spool bore and sealing surfaces.
5. Thoroughly clean both seal grooves and exposed end of spool.

## SPOOL SEAL INSTALLATION

1. Lightly oil and insert one new spool seal in handle end (front) seal groove of valve housing. Verify seal fit by carefully running your finger around exposed edge of seal. Seal should have a perfect ridge with no kinks or twists.
2. Lightly oil valve spool and, starting from positioner end (rear), reintroduce spool into valve housing.
3. Slowly push spool past seal with a twisting motion. Stop when seal groove is exposed on positioner end.



**CAUTION:** Do not pull spool too far, as this will allow seal in front groove to enter a spool groove. Seal may be cut when spool is pushed back.

4. Lightly oil and insert remaining spool seal in bonnet end seal groove. Verify seal fit by carefully running your finger around exposed edge of seal. Seal should have a perfect ridge with no kinks or twists.
5. Return spool to center position with a twisting motion.
6. Reattach spool positioner. Use locite 242 (blue) thread locking compound on spool screw holding positioner parts to spool. Be careful not to over torque this screw and twist it off. Use 7 ft. lb. maximum torque. Slide bonnet in place. Replace bonnet screws. Torque bonnet screws to 5-7 ft. lbs.
7. Replace spool clevis pin and handle assembly.



# VALVE SERVICE

## REPLACING DAMAGED BACKUP RINGS

Backup rings are installed at the factory using a special sizing tool.

1. Do not replace backup rings offered in seal kits unless original ring has been damaged.
2. If backup ring must be replaced, cut replacement backup ring as shown.

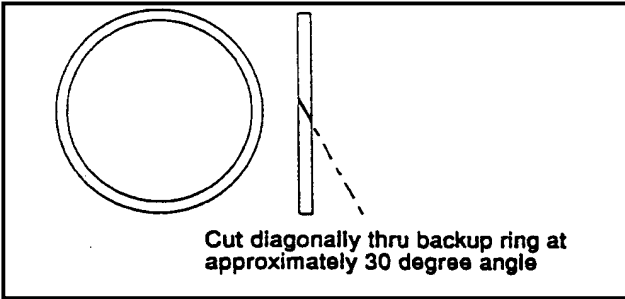

**CAUTION:** Make only one diagonal cut in backup ring. Do not cut backup ring into two pieces.

3. Slip backup ring over cartridge and into place.

## INSTALLING "SC" SPOOL POSITIONER KIT (Item 2 Figure 6)

1. Remove socket head cap screws and bonnet from section.
2. Remove spool from section. Follow instructions in "Spool Seal Removal" section except do not remove seals.
3. Replace parts in "SC" spool positioner kit.

**NOTE:** Spool screw on end of spool is loctited in place. Do not replace unless it is damaged. If spool screw must be replaced, refer to "Replacing Spool Ends" Section.

4. Replace spool in section. Refer to instructions in "Spool Seal Installation" section.
5. Replace bonnet and socket head cap screws.

## REPLACING SPOOL ENDS

1. Spool extensions (handle end) are installed at the factory using Loctite 262. Spool screws (positioner end) are installed at the factory using Loctite 242. Do not replace them unless they are damaged. Use following procedure to replace them.
2. Remove spool from section. Follow instructions in "Spool Seal Removal Section" except do not remove seals.
3. Clamp spool using vice grips on land section of spool not machined for valve bore.
4. Unscrew damaged end.

**NOTE:** Heat may be applied to loosen Loctite.

5. Clean threads with Loctite Primer and install using Loctite 262 for handle ends and Loctite 242 for positioner ends.
- Replace spool in section. Refer to instructions in "Spool Seal Installation" section.

# VALVE SERVICE

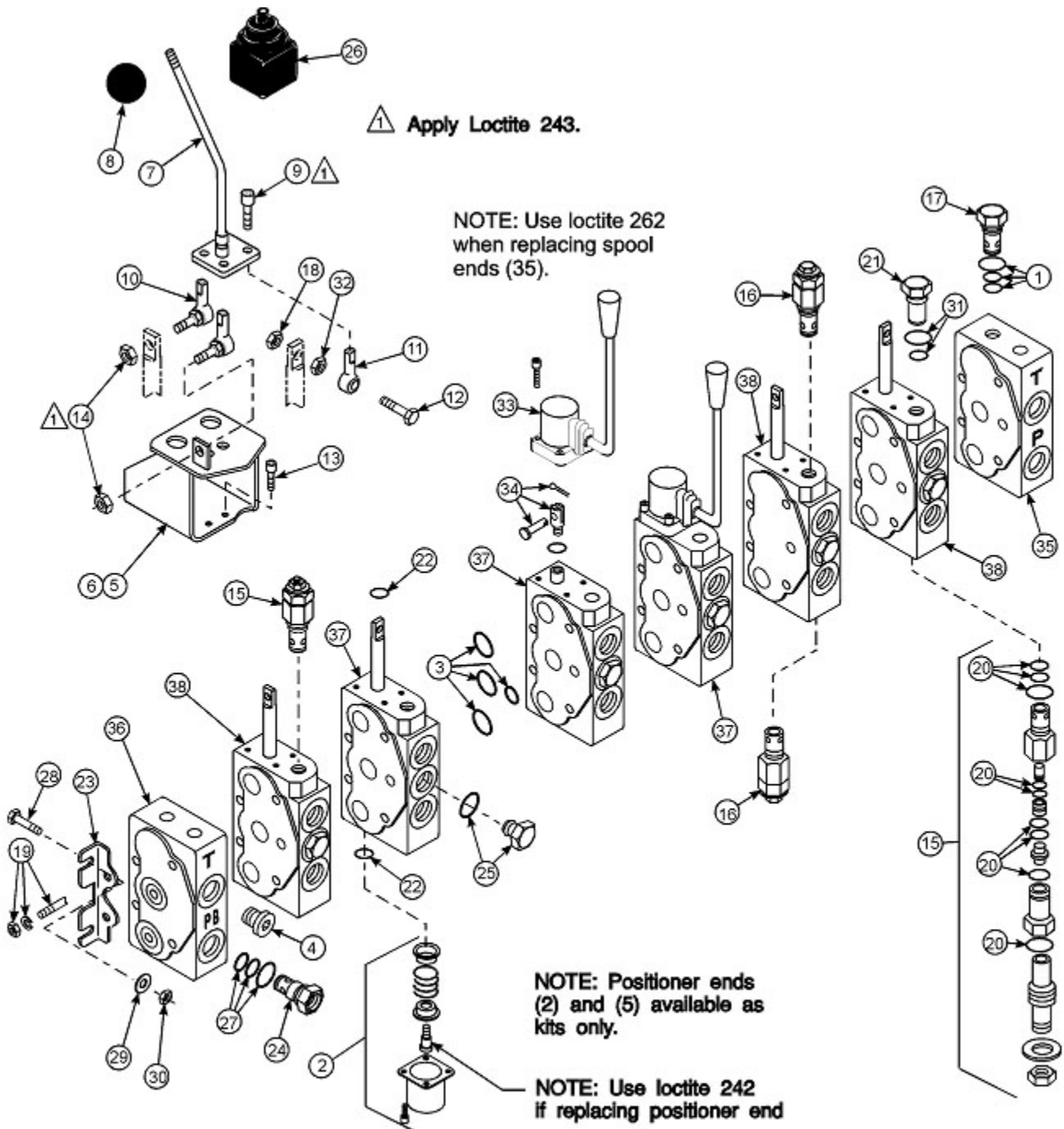

NOTE: Relief cartridges (16), (17) & (18) are not repairable. If service other than to replace seal kit (1) is required, replace complete cartridge.

NOTE: Relief cartridges (15), (16), and (17) are not repairable. If service other than to replace seal kit (1) is required, replace complete cartridge.

# VALVE SERVICE

## REPAIR PARTS - GRESEN V-10 (930300)

ITEM	PART NO.	DESCRIPTION	Qty.
1	932001	SEAL KIT, Main Relief Cartridge (2150 psi)	1
2	932002	SPRING CENTER POSITIONER KIT (New Style "B")	6
3	932003	SEAL KIT, Body Section	7
4	932004	PLUG, Port	1
5	932005	RISER, Right	1
6	932006	RISER, Left (Not Shown)	1
7	930279	HANDLE	2
8	930274	BALL	2
9	**	CREW, Cap, Socket Head, 1/4-28 x 3/4	6
10	930266	ROD END, Assembly	4
11	930273	ROD END	2
12	**	SCREW, Cap, 1/4-20 x 2, Grade 8	2
13	**	SCREW, Cap, Socket Head, #10-24 x 1-1/2	8
14	**	NUT, Hex, 1/4-28	6
15	932007	RELIEF, Work Port, 2500 PSI	3
16	932008	RELIEF, Work Port with Anti Cavitation, 2150 PSI	2
17	932009	RELIEF, Main 2150 PSI	1
18	**	NUT, Lock, 1/4-20	2
19	932010	STUD KIT (Includes 4 stud bolts)	1
20	932011	SEAL KIT, Relief (Work relief cartridges)	4
21	932012	PLUG, No Relief Cavity	2
22	932013	SEAL KIT, Spool (Includes 2 Seals)	6
23	932014	Mounting Bracket	2
24	932015	POWER BEYOND SLEEVE (Optional)	1
25	932016	PLUG KIT, Load Check	6
26	930284	BOOT	2
27	932017	SEAL KIT, Power Beyond	1
28	**	SCREW, Cap, 5/16-18 x 1	4
29	**	WASHER, Flat, 5/16	4
30	**	NUT, Lock, 5/16-18	4
31	932018	SEAL KIT, Work Port Plug	2
32	**	NUT, Hex, 1/4-20	2
33	930293	HANDLE KIT	2
34	932019	CLEVIS & PIN KIT	2
35	932020	INLET COVER	1
36	932021	OUTLET COVER	1
37	932022	VALVE SECTION, 4-Way, 3-Position (Does not include items 16, 17, 19, 34 or 35)	4
38	932023	VALVE SECTION, with long spool (Does not include 16 or 17)	3

\*\* PURCHASE LOCALLY

# PARTS

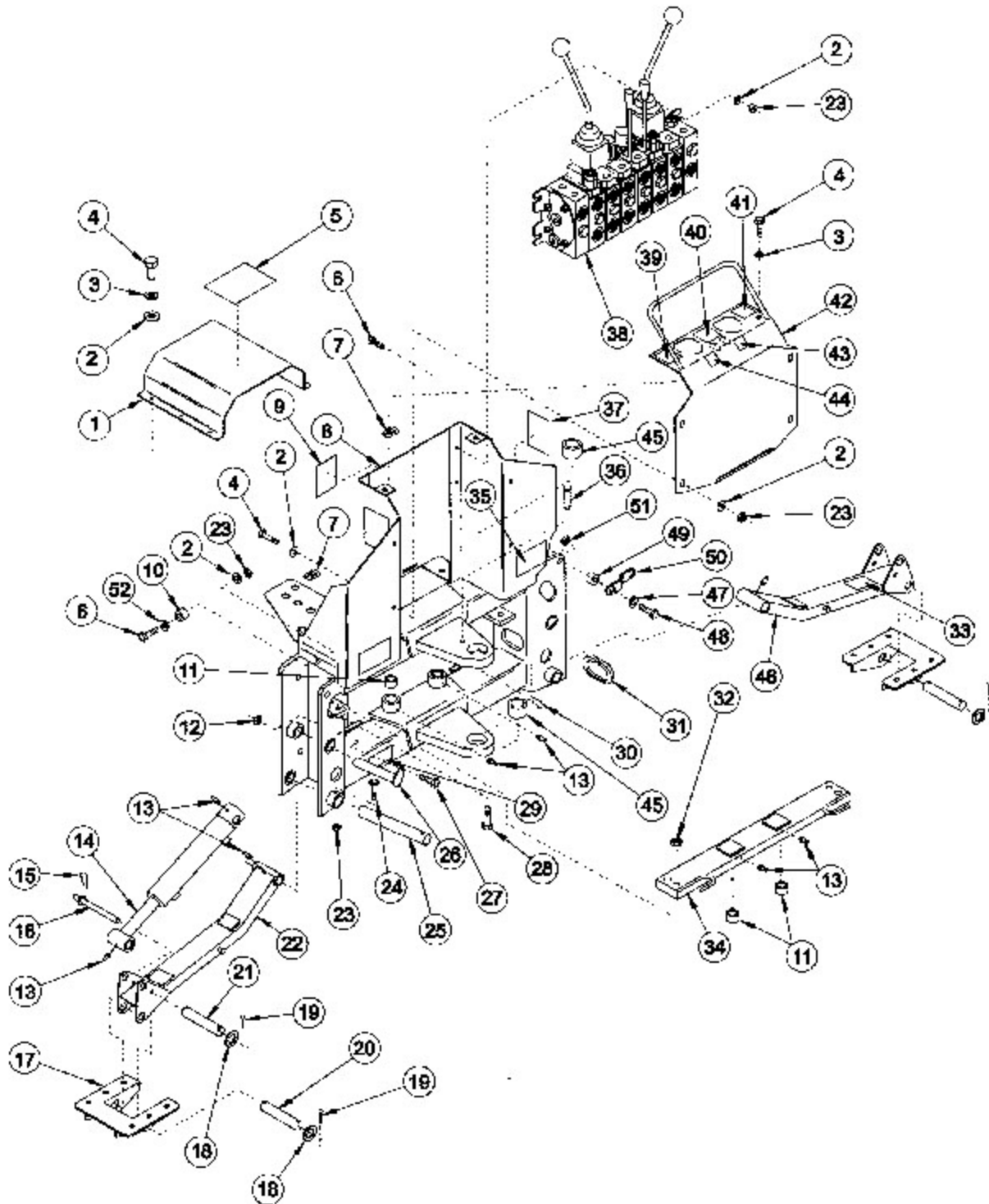

# PARTS

## PARTS LIST - MAINFRAME AND STABILIZERS (Figure 8)

ITEM	PART NO.	DESCRIPTION	Qty.
1	932024	SEAT BRACKET COVER	1
2	**	WASHER, Flat, 5/16	24
3	**	WASHER, Lock, 5/16	8
4	**	SCREW, Cap, 5/16-18 x 3/4	12
5	930265	ANTI SKID SURFACE	1
6	**	SCREW, Cap, 5/16-18 x 1	6
7	930318	SPEED NUT, 5/16	8
8	930298	MAINFRAME	1
9	930289	DECAL, Warning	1
10	930282	RUBBER STOP	2
11	930280	BUSHING 1.25 O.D. X 1.00 I.D. X 1.25 Long	2
12	**	NUT, Lock, 3/8-16	2
13	932025	FITTING, Grease, 1/4-28	10
14	930301	CYLINDER	2
15	**	COTTER PIN, 3/32 x 1.88	2
16	930278	PIN ASSEMBLY	2
17	930281	PAD ASSEMBLY	2
18	932026	BUSHING, Machine	8
19	**	COTTER PIN, 3/16 x 1.50	8
20	932027	PIN, 1.00 x 6.44	2
21	932028	PIN, 1.00 x 5.81	2
22	932029	STABILIZER ASSEMBLY (RIGHT)	1
23	**	NUT, Lock, 5/16-18	12
24	**	SCREW, Cap, 5/16-18 x 2	2
25	932030	PIN, 1.00 x 7.50	2
26	930268	PIN ASSEMBLY, 1.00 x 5.88I	2
27	932031	SHOULDER BOLT, 3/8-16 x 1	2
28	**	SCREW, Cap, 5/8-11 x 2.25	4
29	932032	SERIAL PLATE	1
30	932033	COTTER PIN, Hair,	1
31	932034	TRIM, Plastic, 8.50"	2
32	**	NUT, Lock, 5/8-11	4
33	930290	DECAL, Danger, Crushing, Hazard	2
34	930308	SWING CYLINDER SUPPORT ASSEMBLY w/BUSHINGS	1
35	930288	DECAL, Danger	2
36	930317	PIN, Clevis, 3/4 x 3	1
37	930294	DECAL, Warning	2
38	930300	VALVE	1
39	930331	DECAL, Operation	1
40	930291	DECAL, Warning	1
41	930330	DECAL, Operation	1
42	932035	COVER PLATE ASSEMBLY	1
43	930332	DECAL, Operation	1
44	930333	DECAL, Operation	1
45	930307	BUSHING, 1.88 O.D. x 1.50 I.D. 1.00 Long	2
46	932036	STABILIZER ASSEMBLY (LEFT)	1
47	**	WASHER, FLAT 1/2	2
48	**	1/2-13 X 1.50 CAP SCREW	2
49	932037	SPACER	2
50	932038	LOCK FLAT	2
51	**	NUT, HEX 1/2-13 LOCK	2
52	**	5/16 FLAT WASHER WIDE	2

\*\* PURCHASE LOCALLY

# PARTS

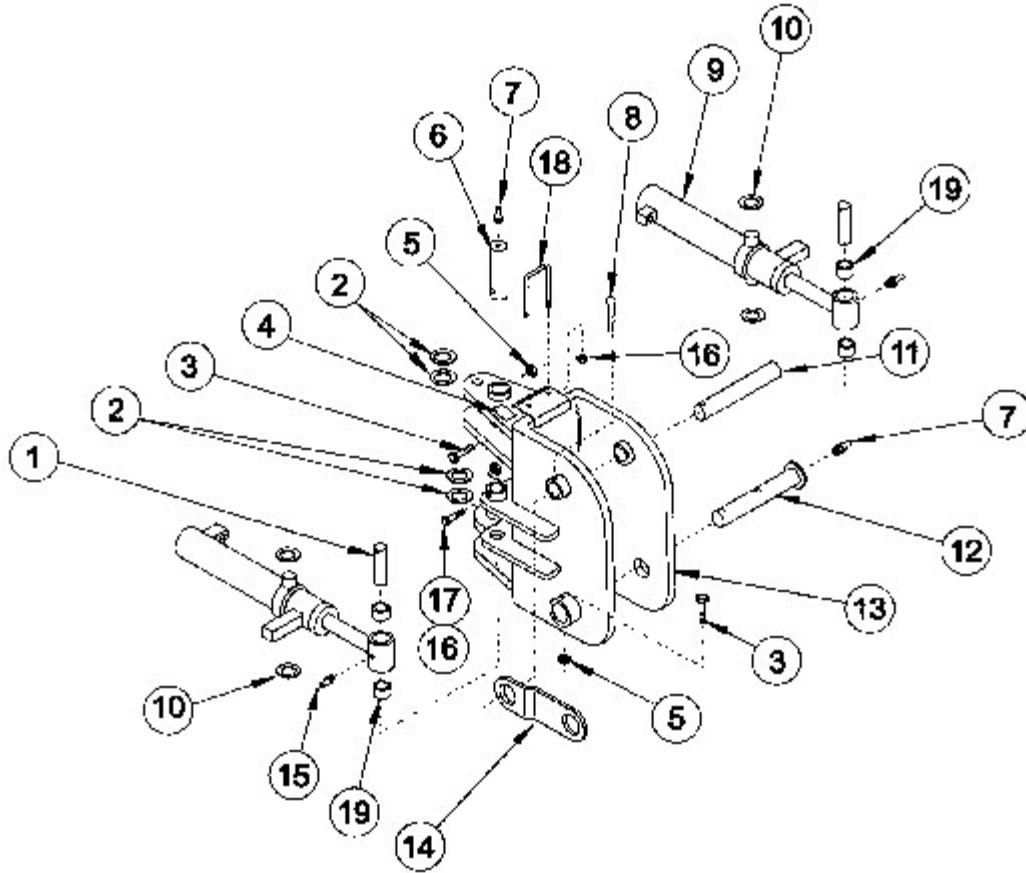

## PARTS LIST - SWING POST AND SWING CYLINDERS

ITEM	PART NO.	DESCRIPTION	Qty.
1	930296	PIN, 1.00 x 4.75	2
2	930287	BUSHING, Machine	8
3	**	SCREW, Cap, 3/8-16 x 2-1/2	3
4	930335	DECAL, Swinglock	1
5	**	NUT, Lock, 3/8-16	3
6	922021	PIN, 1-1/2 x 4.25	2
7	932039	FITTING, Grease, 1/8-27	3
8	**	COTTER PIN, 5/16 x 2.50	1
9	930308	CYLINDER, Swing	2
10	932026	BUSHING, Machine	4
11	930295	PIN, 1 x 7.25	1
12	930314	PIN, 1-1/4 x 7.25	1
13	930312	SWING FRAME ASSEMBLY	1
14	932040	LOCK FLAT	1
15	932025	FITTING, Grease, 1/4-28	2
16	**	NUT, Lock, 5/16-18	4
17	**	SCREW, Cap, 5/16-18 x 2	2
18	920282	CLAMP, U-Bolt	1
19	930304	BUSHING, 1.25 O.D. x 1.00 I.D. x 1.00 LONG	4

\*\* PURCHASE LOCALLY

# PARTS

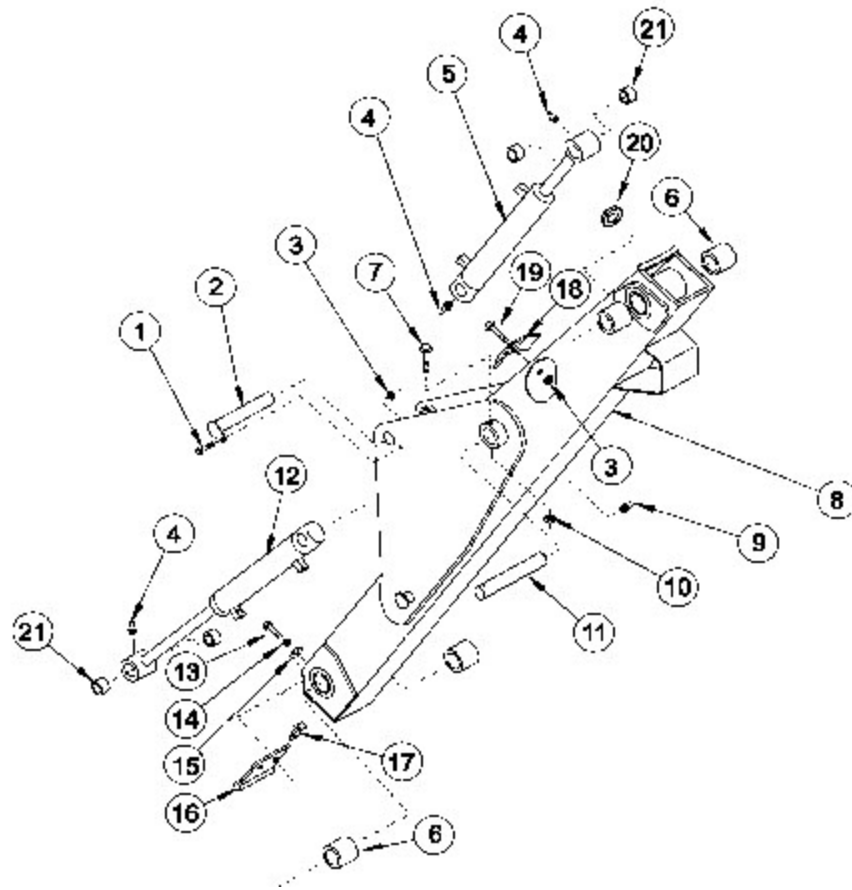

Figure 10  
Boom

## PARTS LIST - BOOM

ITEM	PART NO.	DESCRIPTION	Qty.
1	932031	SHOULDER BOLT, 3/8-16x1	1
2	930267	PIN, 1 x 5	1
3	**	NUT, Lock, 3/8-16	2
4	932025	FITTING, Grease, 1/4-28	3
5	930310	CYLINDER, Dipperstick	1
6	930306	BUSHING, Machine 1.50 O.D. X 1.25 I.D. X 1.50 LONG	4
7	**	SCREW, Cap, 5/16-18 x 2	1
8	930299	BOOMASSEMBLY	1
9	932039	FITTING, Grease, 1/8-27	1
10	**	NUT, Lock, 5/16-18	1
11	930283	PIN, 1 x 6	1
12	930311	CYLINDER, Boom	1
13	**	SCREW, Cap, 5/16-18 x 1	2
14	**	WASHER, Lock, 5/16	2
15	**	WASHER, Flat, 5/16	2
16	932041	HOSE CLAMPASSEMBLY	1
17	930318	SPEED NUT	2
18	932042	CLAMP	1
19	**	SCREW, Cap, 3/8-16 x 1.25	1
20	932043	GROMMET	1
21	932044	BUSHING 1.25 O.D. X 1.00 I.D. X 1.25 LONG	4

\*\* PURCHASE LOCALLY

# PARTS

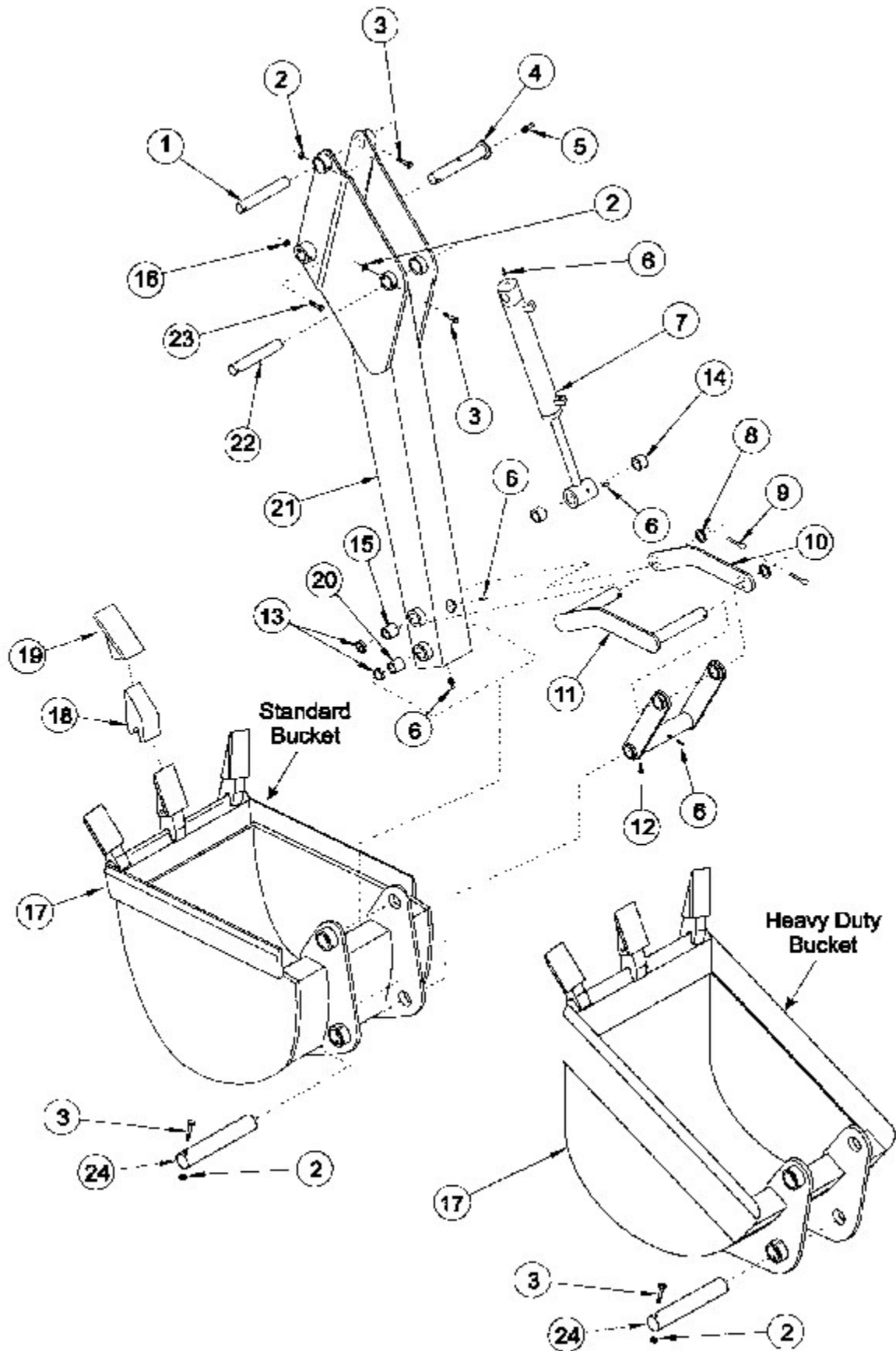



# PARTS

## PARTS LIST - DIPPERSTICK AND BUCKET (Figure 11)

ITEM	PART NO.	DESCRIPTION	Qty.
1	930295	PIN, 1 x 7.25	1
2	**	NUT, Lock, 5/16-18	4
3	**	SCREW, Cap, 5/16-18 x 2	4
4	930314	PIN, 1-1/4 x 7.25	1
5	932039	FITTING, Grease 1/8 - 27	1
6	932025	FITTING, Grease, 1/4-28	5
7	930309	CYLINDER, Bucket	1
8	932026	BUSHING, Machine	2
9	**	COTTER PIN, 1/4 x 1-1/2	2
10	930275	TOGGLE LINK	1
11	930313	TOGGLE LINK ASSEMBLY	1
12	930276	BUCKET LINK ASSEMBLY	1
13	932045	SEAL	4
14	932044	BUSHING 1.25 O.D. X 1.00 I.D X 1.25 LONG	2
15	932047	BUSHING 1.25 O.D. X 1.00 I.D X 1.500 LONG	2
16	**	NUT, Lock, 3/8-16	3
17	*	BUCKET, Complete, (See page 29)	-
18	932046	SHANK, Bucket, 1" Wide (fits standard & heavy duty buckets)	-
19	930286	TOOTH, Bucket, 1-3/4 Wide (fits standard & heavy duty buckets)	-
20	932047	BUSHING, 1.25 O.D. X 1.00 I.D. X 1.50 Long	2
21	930303	DIPPERSTICK ASSEMBLY	1
22	930272	PIN, 1 x 6.25	1
23	**	SCREW, Cap, 3/8-16 x 2-1/2	1
24	932072	PIN, 1 x 6.62	
25	932048	PIN, 1 x 8-1/8	2

\* Buckets not sold as repair part (order as whole goods)

\*\* PURCHASE LOCALLY

# PARTS

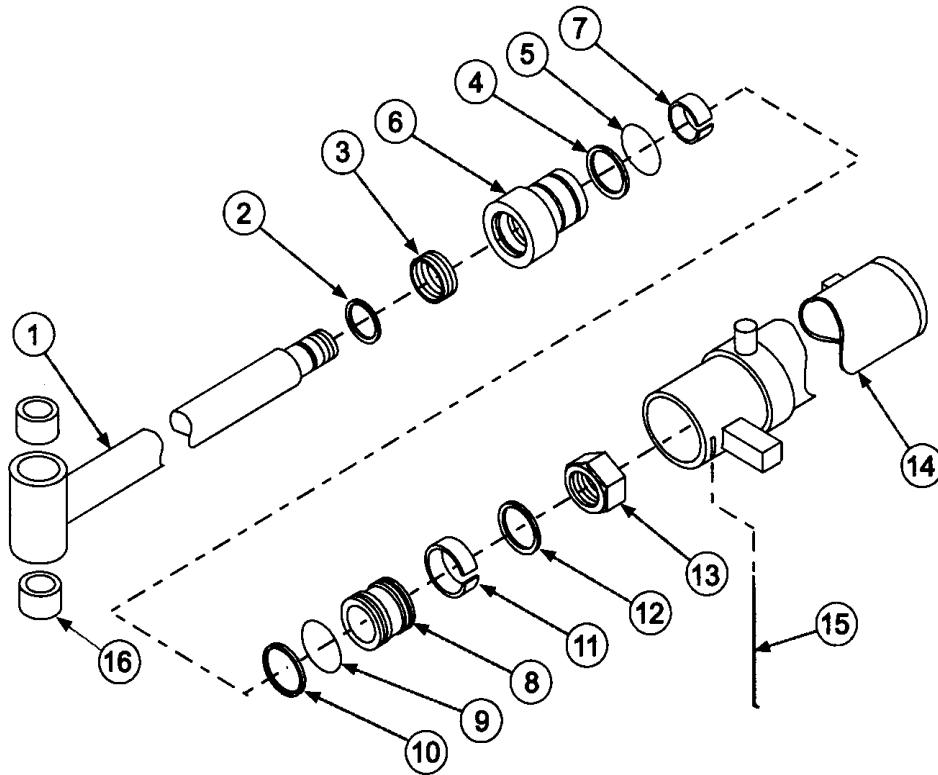

## PARTS LIST - SWING CYLINDERS (2-1/4") - 47463 (Code MC)

ITEM	PART NO.	DESCRIPTION	Qty.
1	932081	ROD, Weldment, 1-3/8" w/BUSHING	1
2	*	RING, Wiper	1
3	*	SEAL, V-Cup	1
4	*	RING, Backup	1
5	*	O-Ring	1
6	932049	HEAD, Cylinder	1
7	*	RING, Wear	1
8	932050	PISTON	1
9	*	O-Ring	2
10	*	SEAL, Piston	1
11	*	RING, Wear	1
12	932051	RING, Steel	1
13	932052	NUT, Lock, 1-14	1
14	932053	CYLINDER TUBE, Weldment	1
15	*	LOCKWIRE	1
16	930304	BUSHING, 1.25 O.D. X 1.00 I.D. X 1.00 Long	4
*	930321	Repair Kit, Includes (*) Items	1

# PARTS

**Figure 14**  
**Bucket Cylinder**

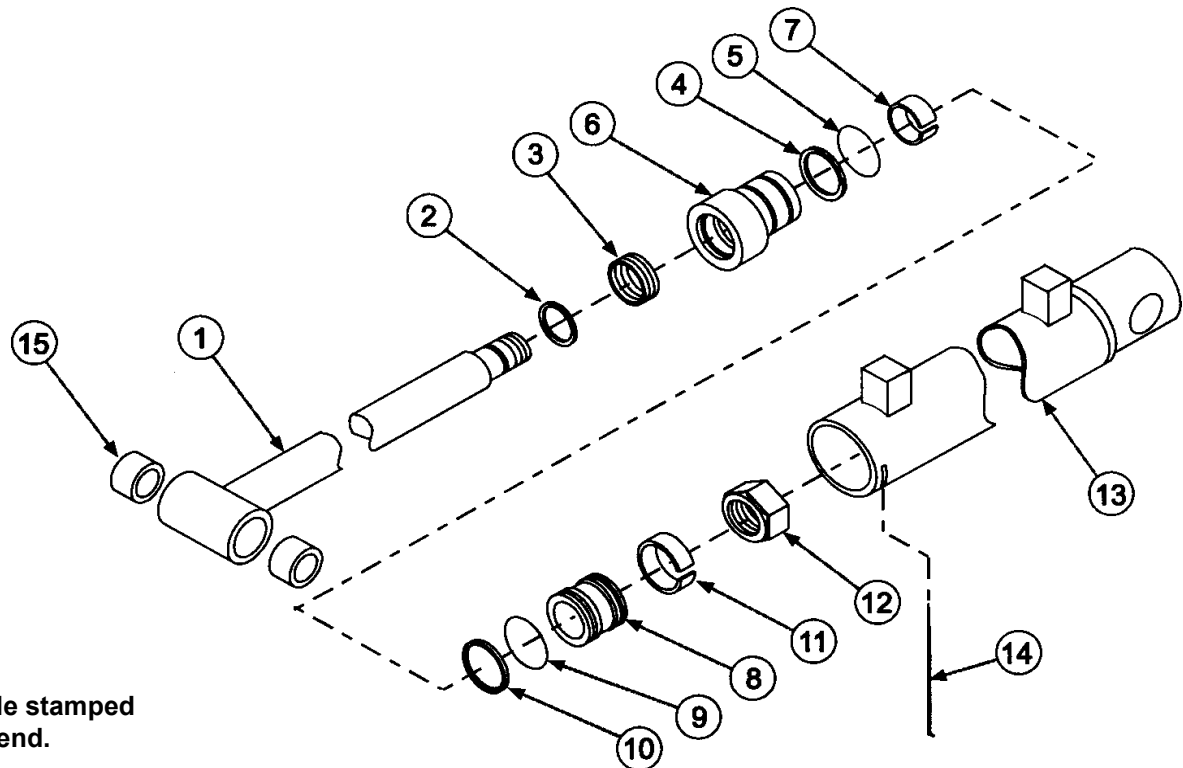

**NOTE: Cylinder code stamped  
Near cylinder base end.**

**PARTS LIST - BUCKET CYLINDER (2-1/4") - 47464 (Code MA) STABILIZER CYLINDER (2-1/4) - 47272 (Code LY)**

ITEM	PART NO.	DESCRIPTION	Qty.
1	930322	ROD, Weldment, 1-3/8" (Bucket Cylinder w/Bushings)	1
	930323	ROD, Weldment, 1-3/8" (Stabilizer Cylinder)	1
2	*	RING, Wiper	1
3	*	SEAL, V-Cup	1
4	*	RING, Backup	1
5	*	O-Ring	1
6	932049	HEAD, Cylinder	1
7	*	RING, Wear	1
8	932054	PISTON	1
9	*	O-Ring	2
10	*	SEAL, Piston	1
11	*	RING, Wear	1
12	932052	NUT, Lock	1
13	930322	CYLINDER TUBE, Weldment (Bucket Cylinder)	1
	932055	CYLINDER TUBE, Weldment (Stabilizer Cylinder)	1
14	*	LOCKWIRE	1
15	932044	BUSHING ( Bucket Cylinder only) 1.25 O.D. X 1.00 I.D. X 1.25 Long (Note: NO BUSHING IN STABILIZER CYLINDER)	2
*	930321	Repair Kit, Includes (*) Items	1

# PARTS

NOTE: Cylinder code stamped  
Near cylinder base end.

Figure 15  
Lift Cylinder

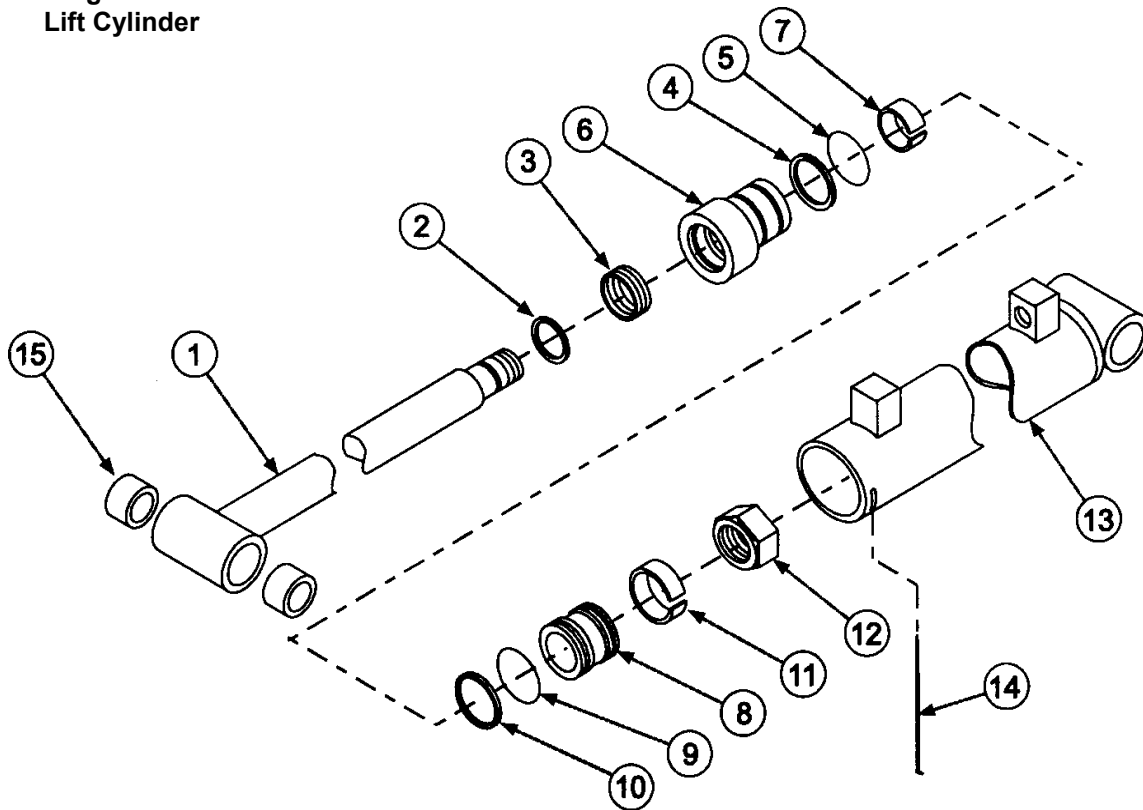

**PARTS LIST - LIFT CYLINDER (2-3/4") - 47466 (Code MB)    DIPPER CYLINDER (2-3/4) - 47465 (Code MD)**

ITEM	PART NO.	DESCRIPTION	Qty.
1	932056	ROD, Weldment, 1-3/8" (Lift Cylinder) w/ Bushings	1
	932057	ROD, Weldment, 1-3/8" (Dipper Cylinder) w/ Bushings	1
2	*	RING, Wiper	1
3	*	SEAL, V-Cup	1
4	*	RING, Backup	1
5	*	O-Ring	1
6	932058	HEAD, Cylinder	1
7	*	RING, Wear	1
8	932059	PISTON	1
9	*	O-Ring	2
10	*	SEAL, Piston	1
11	*	RING, Wear	1
12	932060	NUT, Lock, 1-14	1
13	932061	CYLINDER TUBE, Weldment (Lift Cylinder)	1
	932062	CYLINDER TUBE, Weldment (Dipper Cylinder)	1
14	*	LOCKWIRE	1
NS	930320	Repair Kit, Includes (*) Items	1
15	932044	BUSHING 1.25 O.D. X 1.00 I.D. X 1.25 LONG	2

# PARTS

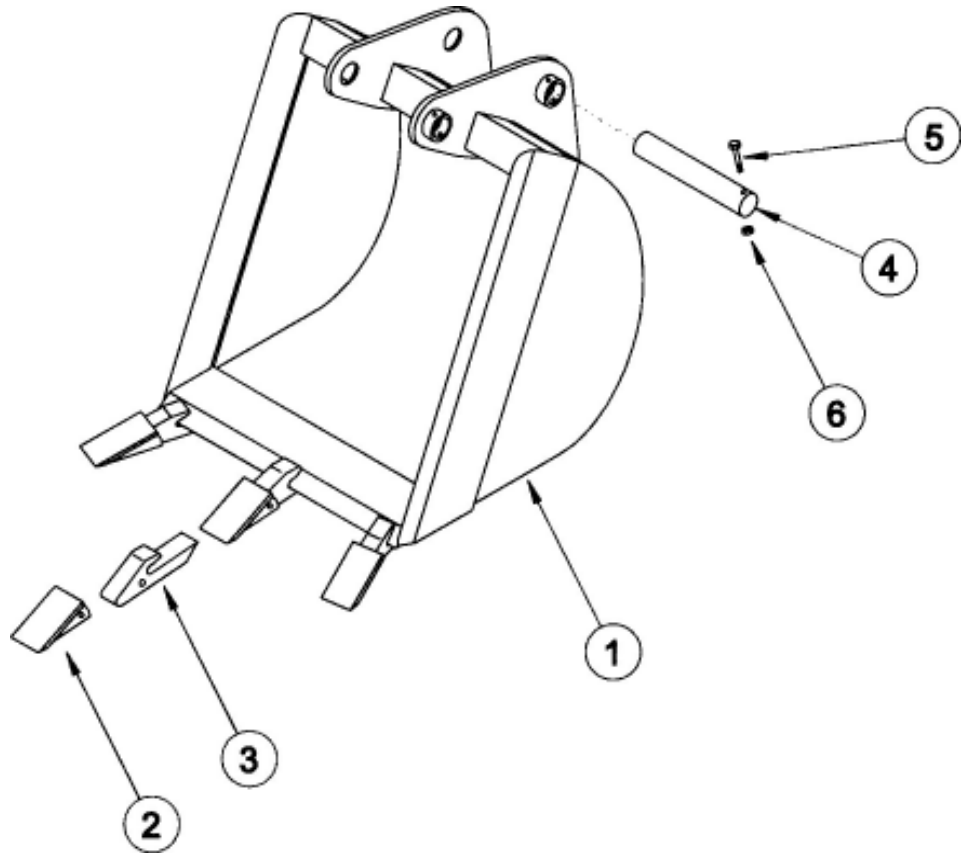

BUCKET MODEL	BUCKET WIDTH Inches	STRUCK CAPACITY Cubic Feet
9"	9	.73
12"	12	1.01
12" HD	12	1.01
16"	16	1.38
18"	18	1.56
18" HD	18	1.56
20"	20	2.11
36" Grave	36	2.78
36" Muck	36	2.78

## PARTSLIST - BUCKETS

ITEM	PART NO.	DESCRIPTION	Qty.
1	930156	BUCKET, 9"	-
	930012	BUCKET, 12"	-
	930180	BUCKET, 16"	-
	930181	BUCKET, 18"	-
	932069	BUCKET, 24"	-
	932070	BUCKET, Grave, 36"	-
	2	930286	TOOTH
932046		SHANK	-

# PARTS

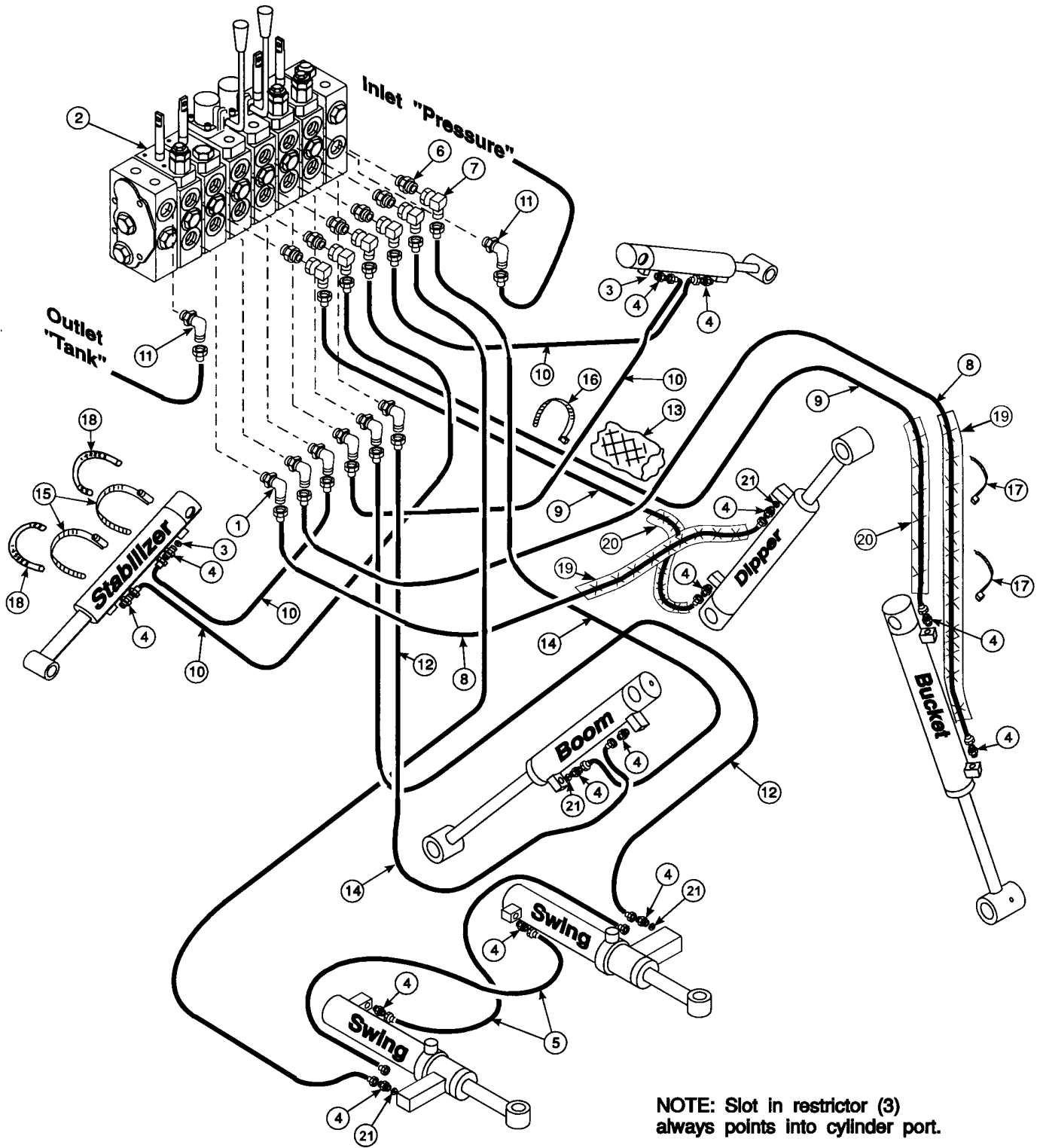

# PARTS

## PARTS LIST - HYDRAULIC HOSES AND FITTINGS (Figure 16)

ITEM	PART NO.	DESCRIPTION	Qty.
1	932073	FITTING, Elbow, 9/16-18 JIC x 3/4 O-Ring, 90°	6
2	930300	VALVE - Gresen V-10	1
3	932074	RESTRICTOR (Stab. Cyl) .063	2
4	930269	FITTING, Adapter,	14
5	930329	HOSE, 1/4 x 24 (Swing Cylinder to Swing Cylinder)	2
6	932075	FITTING, Adapter, 3/4 O-Ring x 9/16 JIC	6
7	922295	FITTING, Elbow, 9/16-18 JIC x 9/16-18 JIC Swivel, 90°	6
8	930328	HOSE, 1/4 x 124 (Dipper & Bucket Rod)	2
9	930326	HOSE, 1/4 x 108 (Dipper & Bucket Base)	2
10	930325	HOSE, 1/4 x 54 (Stabilizer to Valve)	4
11	932076	Fitting, Elbow, 3/4-16 JIC x 3/4-16 O-Ring, 90°	2
12	932077	HOSE, 1/4 x 40 (Swing Cylinder to Valve)	2
13	932078	NYLONSLEEVE	1
14	930327	HOSE, 1/4 x 66	2
15	930319	HOSE CLAMP	4
16	932079	TIE STRAP, Adjustable, 1/2 x 20	1
17	932080	TIE STRAP, Adjustable, 3/16 x 11	10
18	930285	WOVEN COTTON LOOM	4
19	930271	NYLON SLEEVE, 47"	2
20	930270	NYLON SLEEVE, 27"	2
21	930302	RESTRICTOR (.093)	4

